



aerospace
climate control
electromechanical
filtration
fluid & gas handling
hydraulics
pneumatics
process control
sealing & shielding



Racor Filter Division Europe

Engine Air Filtration Systems



ENGINEERING YOUR SUCCESS.

Parker's technical resources provide the correct filtration technologies that conform to your requirements. That's why thousands of manufacturers and equipment users around the world rely on Parker Filtration products and people.



Hydraulic, Lubrication & Coolant Filtration
High-performance filtration systems for protection of machinery in industrial, mobile and military/marine applications.



Filtration & Separation
Complete line of compressed air/gas filtration and separation products; coalescing, particulate and adsorption filters in many applications in many industries.



Racor Fuel Conditioning & Filtration
Parker air, fuel and oil filtration systems provide quality protection for engines operating in any environment, anywhere in the world.



Process & Chemical Fluid Filtration
Liquid filtration systems for beverage, chemical and food processing; cosmetic, paint, water treatment; photo-processing; and micro-chip fabrication.



System Contamination Monitoring
On-line dynamic particle analysis, off-line bottle sampling and fluid analysis and measurement of water content polluting the oil in a system.

Parker Filtration's global reputation as a reliable supplier of superior filtration products is the result of a focused and integrated development and manufacturing system.

Parker Filtration consolidates quality filtration products, manufactured for process filtration, air and gas filtration and separation, fuel conditioning and filtration, fluid power products and hydraulic filter products into one broad-based range that covers many markets and most applications, as detailed here.

Racor The World's Best Filtration

Over 30 years of innovation,
over 30 years of quality...

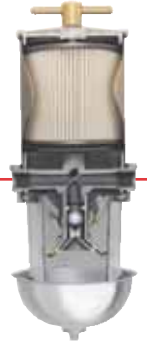

1975

Cold

1975 Racor pioneers integrated fuel heaters, now standard throughout the industry.

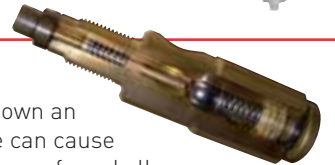

1984

Protection

1984 The Racor Sentinel System shuts down an engine before a major component failure can cause permanent damage. Sentinel remains the preferred all mechanical engine control system.



1987

Standard Equipment

1987 The first Navistar powered Ford E Series and F Series vehicles roll off the production line with the revolutionary, compact and flexible Racor Spin On Series.

1991

The Environment

1991 Along with protecting engines, Racor makes products that protect the environment. Lifeguard is a marine fuel/air separator that prevents fuel from escaping overboard from vent lines during refuelling.

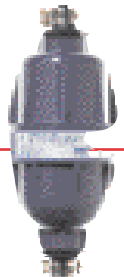

1994

Air

1994 Engines gasping for a breath of fresh air breathe easy with the introduction of synthetic, multi stage Racor "twice the life" air filters.



1996

Plant expansion

1996 In addition to the world class manufacturing facility in Modesto, Racor opens locations in Oklahoma, South Carolina, Brazil, Korea and South Africa. In Europe Morley, West Yorkshire in the UK becomes the centre of excellence in Europe.



2000

UK Facility

2000 Having moved out of Morley into a purpose built factory at nearby Dewsbury in 1998, Racor sees significant growth in Europe. 2000 saw the expansion of manufacturing capability to include all spin on series filters, and the establishment of a state-of-the-art design and test, research and development facility.



2002

High performance air filters

2002 Racor purchases Farr opening up opportunities in medium and heavy duty Engine Air applications.



Contents

Starts with the World's Best Engineering

1969

Diesel Fuel

1969 It all began with a patented, and exceptionally efficient new way to remove water, dirt, rust and algae from diesel fuel.



1983

Technology

1983 Aquabloc® filters debut, and Racor Filter/Separators make another significant leap in filtration efficiency.



1985

Growth

1985 Racor becomes a division of Parker Hannifin Corporation, further strengthening one of the world's most respected brands.



1989

Quality

1989 Racor earns Ford Q1 certification, the first in a series of quality awards from one of the world's leading engine and equipment manufacturers.



1992

Oil

1992 Every bit as vital and every bit as dirty as fuel. The Racor solution is an ingenious one, a cleanable oil filter that puts an end to frequent filter changes and disposal.



1995

CCV Products

1995 Racor starts cleaning up engine rooms with a crankcase ventilation system that keeps oily blow-by from damaging turbochargers and other precision components.



1997

Racor Hydrocarbon

1997 Racor Hydrocarbon Filters and Vessels debut – offering customers flow rates to 1000 gpm and higher.



2001

Global OEM

2001 Racor continues to forge long term relationships with Global OEM companies to produce sound, cost effective engineered solutions to meet specific application requirements.



2007

Ultra high efficiency CCV integration

2008

Lab and engine test facilities

The most trusted name in engine protection

Racor technology takes the guesswork out of engine protection and Racor manufacturing quality and attention to detail ensures every customer gets the filtration and separation solution they are looking for.

To make product selection easier, Racor's extensive range has been catalogued into four market/ application groups detailed below.

Hydrocarbon Filter Vessels and Elements

From the refinery to the injector, at the terminal and on the forecourt, Racor has a hydrocarbon filter vessel and element solution to meet your fuel delivery needs.



Ref: FDRB130GB1

Commercial Fuel Filtration

Everytime you add fuel, you add millions of tiny contaminants...small enough to be invisible, but big enough to destroy injectors, pumps and profitability. Racor's industrial and automotive product range of customer proven spin-on filter/separators, turbine fuel filters and crank case ventilators are the solution.



Ref: FDRB129GB1

Engine Air Filtration

Systems Fresh air. That's what Racor filtration is all about. Because when engines breathe easier they perform better with more power, more torque and with improved fuel economy. Whatever your application, there's a Racor Air Filtration system that will help you and your engine breathe easy.



Ref: FDRB172UK

Leisure Marine and Commercial Marine

Filtration Ask a sailor about engine protection. About filtration, about reliability and performance. Whether they are the master of a superyacht, sailboat, fishing boat or tug, the chances are the one word answer will be the same as it has been for more than three decades...Racor. Marine filtration products trusted across the seven seas.



Ref: Commercial Marine FDRB175UK
Ref: Leisure Marine FDRB134GB1

For further information email:
filtrationinfo@parker.com

Racor Out in Front	4-5	OEM CCV Solutions	19	CCV Systems	26-29
Diesel and Petrol Spin-on Series	6-13	CNG and LPG Filtration	20-21	ECO III & ECO SE	30-31
P-Series	14-15	FBO Filters Vessels	22-23	Accessories	32-33
Turbine Series & Primer Pump	16-18	RVFS Series	24-25	Installation examples/other products	34-35

Light to Medium Duty Industrial Mobile and Marine

ECO Series Spin-On Disposable Air Cleaners

With its revolutionary spin-on design, the completely disposable ECO Series offers faster, safer, more trouble-free service than any other air cleaner today. Built for rugged use, it combines maximum engine protection with fuel-efficient performance and long service life.

The ECO Series provides two significant improvements in engine protection. When the filter loads with dirt and replacement is required, collected dust and debris stay safely contained inside the disposable housing, eliminating the chance of contaminating the air intake system during air filter service. Since the ECO Series uses no clean air gaskets, you never have to worry about gasket leakage. The outlet simply hooks up to the intake with a rubber connection and clamp, creating a leak-tight seal.

Air flow distribution and dust loading are uniform throughout the high-performance filter cone pack, resulting in increased capacity and lower pressure differential for improved horsepower and fuel economy.

All ECO Series Spin-On Filters feature water-resistant media for improved performance and optimum life.

All Eco media are SAE rated to 99.9% efficiency (SAE J726C).

And most importantly, during changeouts, there are no seals or gaskets to replace.



ECO II

The first cone-type filter element that is both tapered and offset

Water-resistant media provides three to five times longer filter life than conventional filters

More useable media area than conventional filters

Media is SAE-rated to provide average efficiency of 99.9% (SAE J726C), with no seals or gaskets to replace



Beaded outlet

Paper pleats are permanently locked in place for reliable performance

Requires no additional room to service element



Applications

Economical, disposable and lightweight

The revolutionary spin-on concept of the compact ECO filter range makes it the ideal choice for truck installations, plus industrial and marine engine packages operating between 150hp and 1000hp (300-2000cfm).

Safer, faster, trouble free servicing is assured with an ECO filter.

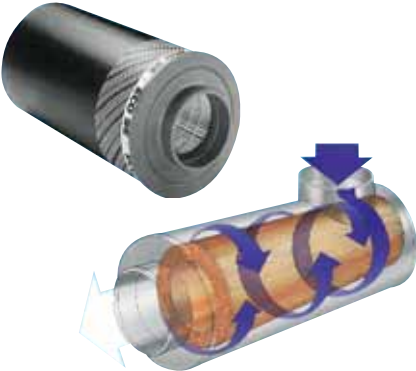

The ECO II was designed to provide lower replacement element cost on an **under hood truck application** due to the 2-piece design. The Inlet Adapter is a separate piece that stays on the truck and is purchased separately.

ECO operation

The tapered offset cone design employed in the ECO filters assures uniform air distribution, minimises air restriction and maximises element service life.

The extended area pleated element itself is fully supported and achieves an efficiency of 99.9% to SAE J726C for optimum engine protection.

Where space is at a premium the fully disposable ECO range is ideal as no additional space is required for element changeout.

The illustration below depicts the ECOLITE and shows the intake airflow from the side. The intake however can also be from one end, offering reverse flow flexibility.



The ECO II used without the Inlet Adapter has become the standard in the Generator Set market. Air Flow is Outside-In with water drain holes around the perimeter.



The ECO II range

Weighing only half as much as conventional filters the side inlet ECO II has all the inherent benefits of the ECO range but employs a cone-type element that is both tapered and offset. This feature ensures that airflow distribution and dust loading are uniform throughout, resulting in lower restriction and better fuel economy. The ECO II can also be rotated to position the air intake at any angle.

ECO-SE

The ECO-SE is the ideal choice for today's smaller fleet vehicles and stationary engines up to 500hp (1000cfm).

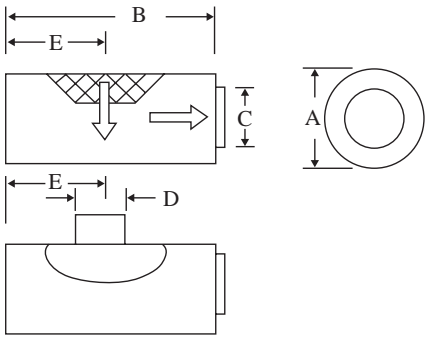

Ordering and Specification

Part No.	Dimensions					Air Flow (CFM)			Weight	
	(Diameter) A	(Length) B	(Outlet) C	(Inlet) D	E	4" w.g.	6" w.g.	8" w.g.	lbs	kg
071338001	9.75	24	6		9.0	750	940	1100	12.5	5.7
071338002	11	24	7		9.0	920	1180	1380	16.2	7.4
071338003	13.5	24	7		9.0	1120	1390	1600	19.0	8.6
071338004	13.5	18	7		9.0	1140	1440	1600	16.9	7.7
071338005	13.5	15	7		7.5	1140	1440	1600	14.0	6.3
071338006	13.5	24	7		9.0	1080	1370	1590	19.36	8.78
071338007	11	24	7		11.5	920	1190	1390	14.51	6.5
071338008	9.75	18	6		9	710	930	1070	9.13	4.14
071338009	13.5	24	7			1210	1600	1910	9.00	5.5

Light to Medium Duty Industrial Mobile and Marine Applications

ECOLITE

The original ECO Series product, the ECOLITE is still the only air filter in the industry that you **can flow air either direction**. This allows a variety of installation options with the same part number replacement element. The ECOLITE can be mounted in any orientation or convenient location; under the hood or outside, direct or remote.

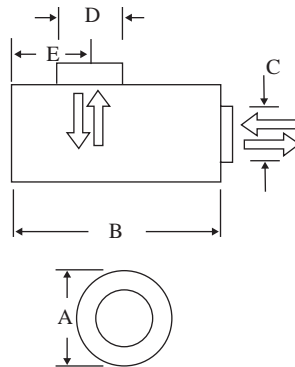

- Tapered offset cone design assures uniform air distribution, minimizes air restriction and maximizes element service life.
- Positive barrier, pleated paper media is set in a superior quality adhesive for a permanent seal.
- The only air filter available with choice of flow directions in a single part number.
- Airflow may enter or exit end opening.

Ordering and Specification

Part No.	Dimensions				Air Flow (CFM)			Weight		
	(Diameter) A	(Length) B	(Outlet) C	(Inlet) D	E	4" w.g.	6" w.g.	8" w.g.	lbs	kg
071338001	9.75	24	6		9.0	750	940	1100	12.5	5.7
071338002	11	24	7		9.0	920	1180	1380	16.2	7.4
071338003	13.5	24	7		9.0	1120	1390	1600	19.0	8.6
071338004	13.5	18	7		9.0	1140	1440	1600	16.9	7.7
071338005	13.5	15	7		7.5	1140	1440	1600	14.0	6.3
071338006	13.5	24	7		9.0	1080	1370	1590	19.36	8.78
071338007	11	24	7		11.5	920	1190	1390	14.51	6.5

ECO-BC (Behind the Cab)

Designed for behind the cab installation on trucks, the ECO-BC must be mounted **vertical with Inside-Out Air Flow**. Also is used for under hood and engine compartment applications. The **rubber drain valve** in the bottom of the unit allows any ingested water or dirt to drain out.

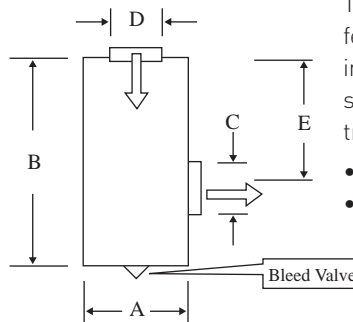

This Spin-On disposable air cleaner features a Slimline design for vertical installations requiring tight or limited space restrictions such as behind the truck cab.

- Inside-out vertical applications only.
- Drain valve in base for water removal.

Ordering and Specification

Part No.	Dimensions				Air Flow (CFM)			Weight		
	(Diameter) A	(Length) B	(Outlet) C	(Inlet) D	E	4" w.g.	6" w.g.	8" w.g.	lbs	kg
071338001	9.75	24	6		9.0	750	940	1100	12.5	5.7
071338002	11	24	7		9.0	920	1180	1380	16.2	7.4
071338003	13.5	24	7		9.0	1120	1390	1600	19.0	8.6
071338004	13.5	18	7		9.0	1140	1440	1600	16.9	7.7
071338005	13.5	15	7		7.5	1140	1440	1600	14.0	6.3
071338006	13.5	24	7		9.0	1080	1370	1590	19.36	8.78
071338007	11	24	7		11.5	920	1190	1390	14.51	6.5

ECO-SE (Small Engine Applications)

The ECO-SE is designed for small engine applications. It also has two unique features. First, it has a urethane outlet tube which allow the filter to be mounted directly to a metal tube or turbo without an additional rubber connection. Second, the standard unit is a straight through air filter, air goes in one end and out the other. Intake adapters are available if you would like to remotely locate the intake. The side inlet version offers additional mounting flexibility.

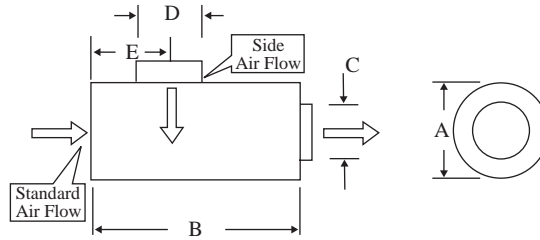

- For light and medium duty applications; smaller mobile and stationary engines up to 300 hp.
- Easy to service, compact, lightweight, high-efficiency design.
- Durable urethane outlet eliminates additional rubber connection.
- Straight-thru design improves pressure differential in smaller engine air intakes.
- Beaded cavity outlet.
- Drain holes for water removal.

Ordering and Specification

Part No.	Dimensions					Air Flow (CFM)			Weight	
	(Diameter) A	(Length) B	(Outlet) C	(Inlet) D	E	4" w.g.	6" w.g.	8" w.g.	lbs	kg
071338001	9.75	24	6		9.0	750	940	1100	12.5	5.7
071338002	11	24	7		9.0	920	1180	1380	16.2	7.4
071338003	13.5	24	7		9.0	1120	1390	1600	19.0	8.6
071338004	13.5	18	7		9.0	1140	1440	1600	16.9	7.7
071338005	13.5	15	7		7.5	1140	1440	1600	14.0	6.3
071338006	13.5	24	7		9.0	1080	1370	1590	19.36	8.78
071338007	11	24	7		11.5	920	1190	1390	14.51	6.5

ECO-SM (Scheduled Maintenance)

The ECO-SM was designed to give **additional mounting flexibility** to the O.E.M. customer, while offering a greater value to the fleet that changes filter elements based on a scheduled maintenance program. Due to the various inlet tube locations, the ECO-SM is ideal for retrofit applications. It is for Outside-In Air Flow only and has drain holes around the perimeter.

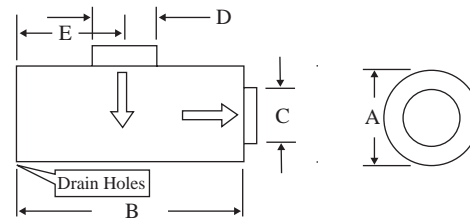

- Easy upgrade for existing air cleaners with separate elements.
- Fast and easy to service with no housing to clean or gaskets to service.
- Beaded outlet.
- Economical scheduled maintenance design
- Choice of three inlet locations to match new or retrofit applications.
- Drain holes for water removal.

Ordering and Specification

Part No.	Dimensions					Air Flow (CFM)			Weight	
	(Diameter) A	(Length) B	(Outlet) C	(Inlet) D	E	4" w.g.	6" w.g.	8" w.g.	lbs	kg
071338001	9.75	24	6		9.0	750	940	1100	12.5	5.7
071338002	11	24	7		9.0	920	1180	1380	16.2	7.4
071338003	13.5	24	7		9.0	1120	1390	1600	19.0	8.6
071338004	13.5	18	7		9.0	1140	1440	1600	16.9	7.7
071338005	13.5	15	7		7.5	1140	1440	1600	14.0	6.3
071338006	13.5	24	7		9.0	1080	1370	1590	19.36	8.78
071338007	11	24	7		11.5	920	1190	1390	14.51	6.5

Light to Medium Duty Industrial Mobile and Marine Applications

ECO-LL (Long Life)

The ECO-LL is similar to the ECO-SM, but is for applications where the customer wants to get the **longest life** from his air filter.

There are also more sizes available. It is also for **Outside-In Air Flow** only and has drain holes around the perimeter.

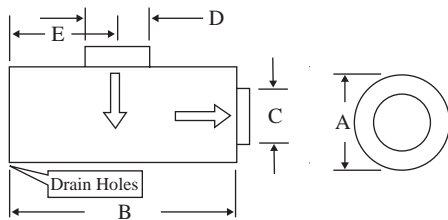

- Spin-On disposable features in a Long Life high performance version.
- Use when extended maintenance intervals, or severe service, or when element life improvement is desired.
- Choice of inlet locations.
- More media surface area than scheduled maintenance style.
- Beaded outlet.
- Drain holes for water removal.

Ordering and Specification

Part No.	Dimensions				Air Flow (CFM)			Weight		
	(Diameter) A	(Length) B	(Outlet) C	(Inlet) D	E	4" w.g.	6" w.g.	8" w.g.	lbs	kg
071338001	9.75	24	6		9.0	750	940	1100	12.5	5.7
071338002	11	24	7		9.0	920	1180	1380	16.2	7.4
071338003	13.5	24	7		9.0	1120	1390	1600	19.0	8.6
071338004	13.5	18	7		9.0	1140	1440	1600	16.9	7.7
071338005	13.5	15	7		7.5	1140	1440	1600	14.0	6.3
071338006	13.5	24	7		9.0	1080	1370	1590	19.36	8.78
071338007	11	24	7		11.5	920	1190	1390	14.51	6.5
071338008	11	24	7		11.5	920	1190	1390	14.51	6.5
071338009	11	24	7		11.5	920	1190	1390	14.51	6.5
071338010	11	24	7		11.5	920	1190	1390	14.51	6.5
071338011	11	24	7		11.5	920	1190	1390	14.51	6.5
071338012	11	24	7		11.5	920	1190	1390	14.51	6.5
071338013	11	24	7		11.5	920	1190	1390	14.51	6.5
071338014	11	24	7		11.5	920	1190	1390	14.51	6.5
071338015	11	24	7		11.5	920	1190	1390	14.51	6.5
071338016	11	24	7		11.5	920	1190	1390	14.51	6.5
071338017	11	24	7		11.5	920	1190	1390	14.51	6.5
071338018	11	24	7		11.5	920	1190	1390	14.51	6.5
071338019	11	24	7		11.5	920	1190	1390	14.51	6.5
071338021	11	24	7		11.5	920	1190	1390	14.51	6.5
071338022	11	24	7		11.5	920	1190	1390	14.51	6.5
071338023	11	24	7		11.5	920	1190	1390	14.51	6.5
071338024	11	24	7		11.5	920	1190	1390	14.51	6.5
071338025	11	24	7		11.5	920	1190	1390	14.51	6.5

Mounting Clamps

Ordering and Specification

Dimensions

Part No.	A	B	C	ECO II	ECO-SE	ECO-SM	ECOLITE	ECO-BC	ECO-LL
071338001	9.80	4.50	5.50	3	3	3	3	3	3
071338001	9.80	4.50	5.50	3	3	3	3	3	3
071338001	9.80	4.50	5.50	3	3	3	3	3	3
071338001	9.80	4.50	5.50	3	3	3	3	3	3
071338001	9.80	4.50	5.50	3	3	3	3	3	3
071338001	9.80	4.50	5.50	3	3	3	3	3	3
071338001	9.80	4.50	5.50	3	3	3	3	3	3
071338001	9.80	4.50	5.50	3	3	3	3	3	3
071338001	9.80	4.50	5.50	3	3	3	3	3	3

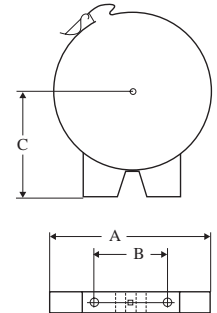

Two required



Medium to Heavy Duty Industrial M

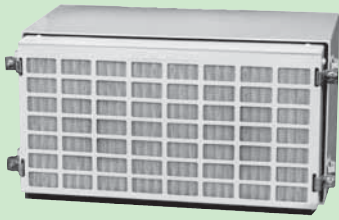

ECO Series Spin-On Disposable Air Cleaners

UniPamic Series Air Cleaners provide unmatched engine protection for a wide range of equipment, from on-highway trucks to compressors, stationary engines to marine engines.

Greatest Protection – The Pamic filter element has an average efficiency rating of 99.9% (SAE J726). It begins at a high level and continues to increase throughout the life of the filter.

Extended Service Life – The unique construction of the Pamic element with its exclusive mechanical pleat separation, provides more usable filter area than any competitive air cleaner, thus offering longer element life. UniPamic models feature an efficient moisture separator panel which removes over 90% of the water that may enter the face of the air cleaner. AutoPamic® models can be upgraded to include a gravity-discharged dust pre-cleaner. RotoPamic® models are upgradeable to either a compressed air or exhaust-aspirated pre-cleaner. An optional, easy-to-use service indicator tells when to change the filter element assuring maximum usage and lowest operating filter costs.

Increased Horsepower, Reduced Fuel Consumption – With its low intake air restriction and its greater effective media area than other dry-type air cleaners, the Pamic Series offers improved fuel economy and lowers per hour operating costs.

Easy To Service – No special tools or techniques, dirt is held inside the pleated filter element tubes. The filter is replaced from the dirty side of the air cleaner, reducing the danger of engine contamination. Because it is an integral part of the filter element, there are no separate gaskets to replace.

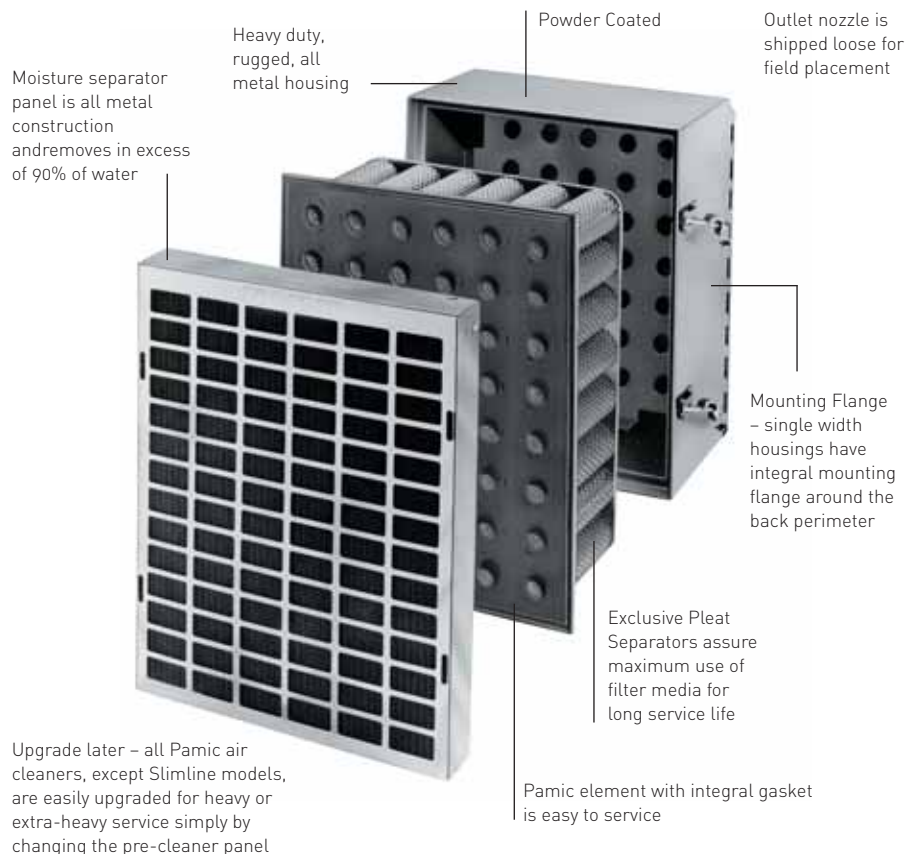

Two Stage Medium to Extra Heavy Service Air Cleaners

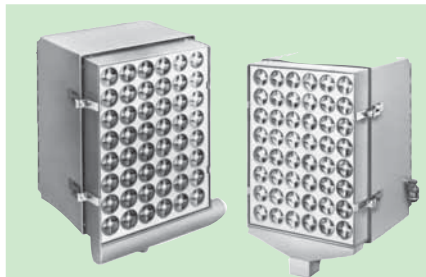

AutoPamic Air Cleaners For Medium and Heavy

Medium service includes most on and off-highway uses such as gravel and ready-mix trucks, outdoor generator sets, garbage trucks, fire trucks, air compressors and pumps.

This AutoPamic air cleaner model with a gravity discharge pre-cleaner is the easiest to install. It may be used on all types of engines.

Note: While total system efficiency is 99.9%, this pre-cleaner is 86% efficient (per SAE J726c).

AutoPamic & RotoPamic Sizing

The chart below shows the number of filter tubes needed to meet engine airflow requirements. Match the CFM of your engine to the type of service the air cleaner will experience. recommended air cleaner size, for type of service shown, has been calculated for an optimum range of engine intake restriction, dirt holding capacity and filter service life.

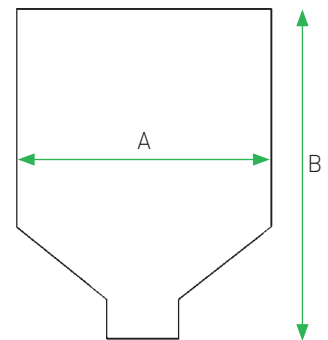

Sizing Specifications

RotoPamic Air Cleaners

Heavy service includes off-highway trucks, motor graders, crawler tractors, scrapers, cranes and shovels. Extra heavy service includes such equipment as large scrapers, rock drills, rough terrain cranes and shovels, rock drilling and quarrying compressors, and full-tracked low speed tractors. These pre-cleaners provide maximum service life of the disposable Pamic filter element.

Positive Pressure Drain System

Positive pressure bleed systems can be used on all turbocharged engines and two-cycle Detroit Diesel turbocharged or naturally aspirated engines. They can also be used wherever a continuous source of compressed air (4 PSIG or greater) is available, such as the receiver tank on an air compressor.

Number of tubes in air filter	Rotopamic		Autopamic			
	Positive pressure bleed		Gravity discharge			
	Maximum airflow		Maximum airflow			
	Heavy & extra heavy service		Medium service		Heavy service	
	CFM	m ³ /h	CFM	m ³ /h	CFM	m ³ /h
4*	-	-	-	-	-	-
6	-	-	180	305	135	230
9	-	-	180	305	135	230
12	-	-	180	305	135	230
16	-	-	180	305	135	230
20	-	-	180	305	135	230
24	-	-	180	305	135	230
32	-	-	180	305	135	230
40	-	-	180	305	135	230
48	-	-	180	305	135	230
64	-	-	180	305	135	230
2-40 [†]	-	-	180	305	135	230
2-48 [†]	-	-	180	305	135	230
2-64 [†]	2175	3695	2560	4350	1920	3260

* On special order only.

† Indicates two pre-cleaners and two filter elements in a single housing. On exhaust aspirated models, a single aspirator is used.

Basic two stage kits include:

Moisture Separator panel

- Pamic Filter Element
- Air Cleaner Housing with integral
- Pamic Filter Element
- Air Cleaner Housing with integral
- Air Cleaner Housing with integral
- Air Cleaner Housing with integral

Positive Pressure

- Pamic Filter Element
- Air Cleaner Housing with integral
- Pamic Filter Element

Positive Pressure Bleed System Plumbing Kit (to be ordered separately)

Application	Ordering Number	Parts included
All engines where (except Detroit Diesel 2-cycle) where connection is taken from side of turbocharger	061999000	Check Valve for prcleaner dust pin.Turbocharger hose fitting. Hose clamps
For Detroit Diesel 2-cycle engines only, where connection is made to air box. Specify engine model & rpm	See Racor Installation Bulletin	Air box fitting. Special air box cover (when required). Hose clamps.

* Order 3/4" (19.1mm) high-temperature silicone hose separately.

Note: For positive pressure plumbing kit for double housings, see your Racor representative.

Ordering and Specification - Bleed Systems

Part No.	Dimensions				Air Flow (CFM)			Weight		
	(Diameter) A	(Length) B	(Outlet) C	(Inlet) D	E	4" w.g.	6" w.g.	8" w.g.	lbs	kg
071338001	9.75	24	6		9.0	750	940	1100	12.5	5.7
071338002	11	24	7		9.0	920	1180	1380	16.2	7.4
071338003	13.5	24	7		9.0	1120	1390	1600	19.0	8.6
071338004	13.5	18	7		9.0	1140	1440	1600	16.9	7.7
071338005	13.5	15	7		7.5	1140	1440	1600	14.0	6.3
071338006	13.5	24	7		9.0	1080	1370	1590	19.36	8.78
071338007	11	24	7		11.5	920	1190	1390	14.51	6.5
071338008	11	24	7		11.5	920	1190	1390	14.51	6.5
071338009	11	24	7		11.5	920	1190	1390	14.51	6.5
071338010	11	24	7		11.5	920	1190	1390	14.51	6.5
071338011	11	24	7		11.5	920	1190	1390	14.51	6.5
071338012	11	24	7		11.5	920	1190	1390	14.51	6.5
071338013	11	24	7		11.5	920	1190	1390	14.51	6.5
071338014	11	24	7		11.5	920	1190	1390	14.51	6.5
071338015	11	24	7		11.5	920	1190	1390	14.51	6.5
071338016	11	24	7		11.5	920	1190	1390	14.51	6.5
071338017	11	24	7		11.5	920	1190	1390	14.51	6.5
071338018	11	24	7		11.5	920	1190	1390	14.51	6.5
071338019	11	24	7		11.5	920	1190	1390	14.51	6.5
071338021	11	24	7		11.5	920	1190	1390	14.51	6.5
071338022	11	24	7		11.5	920	1190	1390	14.51	6.5

* Four tube model is special order only.

† Indicates two moisture separator panels and two filter elements in a single housing.

* Airflow capacities beyond maximum recommendations

Medium to Extra Heavy Duty Applications

Features

Easy to Install

Available in three sizes, for either horizontal or vertical mounting. The integral mounting flange meets the needs of most “bolt-on” applications. A wide selection of flexible fittings, clamps and couplings to connect the air cleaner to the engine intake is also available.

Maintenance is Simple

No special skills or tools are required to change the filter element. Servicing is quick and clean. The long, effective life of the DynaCell reduces maintenance... a special advantage in remote installations.

Single Stage Air Cleaner

- Designed originally as a low profile under hood engine air cleaner for frontal air intake systems on-highway trucks, the DynaCell is now used in a variety of applications where a low profile and high efficiency are required.
- **Applications Include:** Off highway and logging trucks, agricultural tractors and motor graders, construction and mining equipment. Severe service applications include large scrapers, rock drills, cranes, shovels and low speed track type tractors.

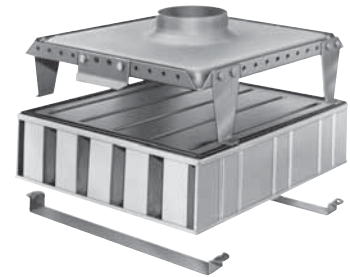

Two and Three-Stage:

In addition to the primary DynaCell element, and your choice of SuperClone Pre-Cleaners, a third stage safety filter is also available. The pleated paper safety filter is housed in a deeper plenum than the two-stage model and provides the ultimate protection.

Easy to install

available in three sizes, for either horizontal or vertical mounting. The integral mounting flange meets the needs of most bolt-on applications. A wide selection of flexible fittings, clamps and couplings to connect the air cleaner to the engine intake is also available.

SuperClone Pre-Cleaner

For heavy and extra duty service, the SuperClone Pre-Cleaner is recommended. SuperClone removes most of the airborne dust prior to it reaching the DynaCell element, extending the systems useful service life.

Two models are available:

- Gravity discharge for heavy service
- Positive pressure aspirated

For applications requiring heavy service, exhaust aspirated or positive pressure aspirated versions are recommended.

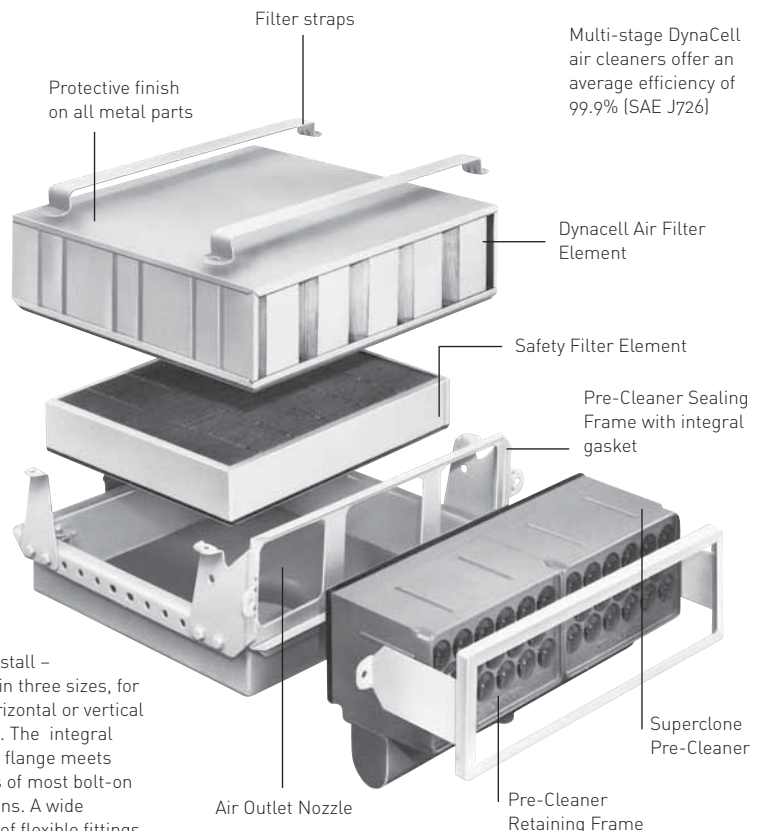

Easy to install – available in three sizes, for either horizontal or vertical mounting. The integral mounting flange meets the needs of most bolt-on applications. A wide selection of flexible fittings, clamps and couplings to connect the air cleaner to the engine intake is also available.

No special tools are required to change the filter element. Servicing is quick and clean.



Positive Pressure Bleed Systems Plumbing Kit for Turbocharged 4-Cycle Engines (Included with Positive Pressure SuperClones)

Application	Part No.	Parts included
All engines where connection is taken from pressure side of turbocharger	061999000 for T-512 & T-519	Plumbing fittings, clamps and check valve. 3/4" high-temp silicone hose is not included
	062215000 for T-528	

Ordering and Specification

Horizontal Dynacell Model	Gravity Discharge		Positive Pressure Aspirated*		Nozell Size	Separate Nozzle Ordering Number	
	With Nozell	Without Nozell	With Nozell	Without Nozell			
T-512	two-stage	066386002	066386002	066386002	066386002	5"	041199004
	three-stage	066386002	6	9.0	750	5"	1100
T-512	two-stage	066386002	6	9.0	750	5"	1100
	three-stage	066386002	6	9.0	750	5"	1100
T-512	two-stage	066386002	6	9.0	750	7"	1100
	three-stage	066386002	6	9.0	750	7"	1100

Horizontal Dynacell Model	Gravity Discharge		Positive Pressure Aspirated*		Nozell Size	Separate Nozzle Ordering Number	
	With Nozell	Without Nozell	With Nozell	Without Nozell			
T-512	two-stage	066386002	066386002	066386002	066386002	5"	041199004
	three-stage	066386002	6	9.0	750	5"	1100
T-512	two-stage	066386002	6	9.0	750	5"	1100
	three-stage	066386002	6	9.0	750	5"	1100
T-512	two-stage	066386002	6	9.0	750	7"	1100
	three-stage	066386002	6	9.0	750	7"	1100

* Four tube model is special order only.
 † Indicates two moisture separator panels and two filter elements in a single housing.
 * Airflow capacities beyond maximum recommendations
 * Airflow capacities beyond maximum recommendations

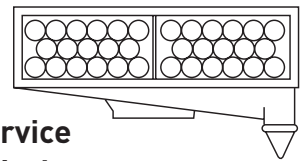

Heavy Service Gravity Discharge

The gravity discharge SuperClone is the easiest to install. No additional ducting or pressure lines are required. It removes up to 86% (SAE J726) of the intake air dust load.

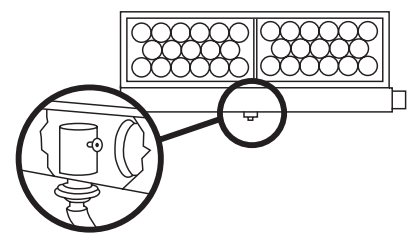

Extra Heavy Service Positive Pressure Aspirated

The positive pressure SuperClone is designed for the heaviest dirt concentrations. Aspirator uses compressed air from engine air intake manifold, air box, or air compressor receiver tank. Air pressures from 4-100 psig are suitable for aspirator. Removes up to 94% (SAE J726) of the dirt entering the air cleaner.

AFSF Series



Applications

Racor Standard Air Filters are designed to be connected to the air intake of the gasoline or diesel engine.

Applications include:

- Agricultural machinery
- Earth-moving equipment.
- Stationary engines; generator sets
- Trucks, buses & recreational vehicles
- Material handling equipment
- Snow removal equipment & street sweepers.

Medium Standard Air Filters

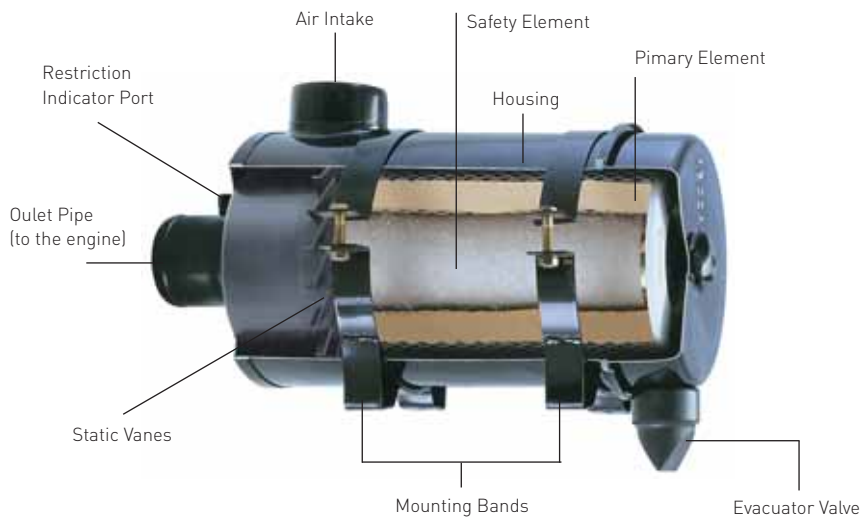

How they work

Air flows through static vanes (plastic or metal) which causes the air to spin. Centrifugal force separates the heaviest impurities (dust, dirt, insects and other debris) from the air stream. These contaminants are discharged automatically through an integral evacuator valve. Only purified air flows to the air filter elements (primary and safety stages of filtration).

Ordering and Specification

Model	Airflow Range	Horsepower Range	Weight		Max Length	Max Diameter	Inlet Size	Outlet Size	Primary Element	Safety Element
			(with filter elements)							
AFSF4	988 to 1517 (28.0 to 43.0 m ³ /min)	320 to 450 HP (239 to 335 KW)	78.65 lbs (35.70 kg)	15.15"	(385 mm)	18.11"	5.25"	5.25"	AR246501	AS6121
AFSF6	988 to 1517 (28.0 to 43.0 m ³ /min)	320 to 450 HP (239 to 335 KW)	78.65 lbs (35.70 kg)	15.15"	(385 mm)	18.11"	5.25"	5.25"	AR246501	AS6121
AFSF8	988 to 1517 (28.0 to 43.0 m ³ /min)	320 to 450 HP (239 to 335 KW)	78.65 lbs (35.70 kg)	15.15"	(385 mm)	18.11"	5.25"	5.25"	AR246501	AS6121
AFSF12	988 to 1517 (28.0 to 43.0 m ³ /min)	320 to 450 HP (239 to 335 KW)	78.65 lbs (35.70 kg)	15.15"	(385 mm)	18.11"	5.25"	5.25"	AR246501	AS6121
AFSF15	988 to 1517 (28.0 to 43.0 m ³ /min)	320 to 450 HP (239 to 335 KW)	78.65 lbs (35.70 kg)	15.15"	(385 mm)	18.11"	5.25"	5.25"	AR246501	AS6121
AFSF18	988 to 1517 (28.0 to 43.0 m ³ /min)	320 to 450 HP (239 to 335 KW)	78.65 lbs (35.70 kg)	15.15"	(385 mm)	18.11"	5.25"	5.25"	AR246501	AS6121
AFSF20	988 to 1517 (28.0 to 43.0 m ³ /min)	320 to 450 HP (239 to 335 KW)	78.65 lbs (35.70 kg)	15.15"	(385 mm)	18.11"	5.25"	5.25"	AR246501	AS6121
AFSF21	988 to 1517 (28.0 to 43.0 m ³ /min)	320 to 450 HP (239 to 335 KW)	78.65 lbs (35.70 kg)	15.15"	(385 mm)	18.11"	5.25"	5.25"	AR246501	AS6121
AFSF310	988 to 1517 (28.0 to 43.0 m ³ /min)	320 to 450 HP (239 to 335 KW)	78.65 lbs (35.70 kg)	15.15"	(385 mm)	18.11"	5.25"	5.25"	AR246501	AS6121
AFSF430	988 to 1517 (28.0 to 43.0 m ³ /min)	320 to 450 HP (239 to 335 KW)	78.65 lbs (35.70 kg)	15.15"	(385 mm)	18.11"	5.25"	5.25"	AR246501	AS6121



Applications

Racor Combination Dynamic Pre-Cleaner / Air Filters are specifically designed to be connected to the air intake of gasoline and diesel engines. The advantages of the systems include their compact size and ease of installation. The three-stage air filtration systems are designed with only one connection to the engine.

Applications include:

- Agricultural machinery
- Earth-moving equipment.
- Stationary engines; generator sets
- Trucks, pick-ups, off road vehicles
- Material handling equipment
- Snow removal equipment & street sweepers.

Heavy Duty Combination Dynamic Pre-Cleaners / Filters



Features and Benefits

- Pre-Cleaners remove up to 90% of impurities from intake air before the air enters the filter elements.
- Extends engine air filter life.
- Reduces down time.
- Prolongs engine and turbocharger life.
- Saves on fuel costs.
- Safety element is standard in most models.

Ordering and Specification

Model	Airflow Range	Horsepower Range	Weight		Max Length	Max Diameter	Inlet Size	Outlet Size	Primary Element	Safety Element			
			(with filter elements)										
AFSF4	988 to 1517 (28.0 to 43.0 m3/min)	320 to 450 HP (239 to 335 KW)	78.65 lbs (35.70 kg)	15.15"	(385 mm)	18.11"	(385 mm)	5.25"	(133 mm)	5.25"	(385 mm)	AR246501	AS6121
AFSF6	988 to 1517 (28.0 to 43.0 m3/min)	320 to 450 HP (239 to 335 KW)	78.65 lbs (35.70 kg)	15.15"	(385 mm)	18.11"	(385 mm)	5.25"	(133 mm)	5.25"	(385 mm)	AR246501	AS6121
AFSF8	988 to 1517 (28.0 to 43.0 m3/min)	320 to 450 HP (239 to 335 KW)	78.65 lbs (35.70 kg)	15.15"	(385 mm)	18.11"	(385 mm)	5.25"	(133 mm)	5.25"	(385 mm)	AR246501	AS6121
AFSF12	988 to 1517 (28.0 to 43.0 m3/min)	320 to 450 HP (239 to 335 KW)	78.65 lbs (35.70 kg)	15.15"	(385 mm)	18.11"	(385 mm)	5.25"	(133 mm)	5.25"	(385 mm)	AR246501	AS6121
AFSF15	988 to 1517 (28.0 to 43.0 m3/min)	320 to 450 HP (239 to 335 KW)	78.65 lbs (35.70 kg)	15.15"	(385 mm)	18.11"	(385 mm)	5.25"	(133 mm)	5.25"	(385 mm)	AR246501	AS6121
AFSF18	988 to 1517 (28.0 to 43.0 m3/min)	320 to 450 HP (239 to 335 KW)	78.65 lbs (35.70 kg)	15.15"	(385 mm)	18.11"	(385 mm)	5.25"	(133 mm)	5.25"	(385 mm)	AR246501	AS6121
AFSF20	988 to 1517 (28.0 to 43.0 m3/min)	320 to 450 HP (239 to 335 KW)	78.65 lbs (35.70 kg)	15.15"	(385 mm)	18.11"	(385 mm)	5.25"	(133 mm)	5.25"	(385 mm)	AR246501	AS6121
AFSF21	988 to 1517 (28.0 to 43.0 m3/min)	320 to 450 HP (239 to 335 KW)	78.65 lbs (35.70 kg)	15.15"	(385 mm)	18.11"	(385 mm)	5.25"	(133 mm)	5.25"	(385 mm)	AR246501	AS6121

Heavy Duty On-Highway Pre-Cleaners

For Mobile Equipment Applications

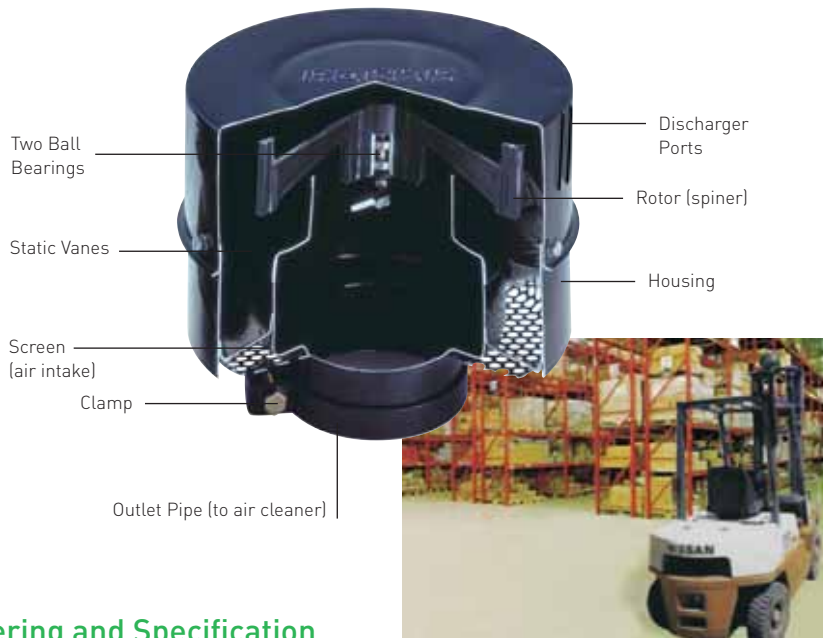

Applications

Racor Engine Air Pre-Cleaners are designed to be mounted on or connected to the air filter intake of a gasoline or diesel engine air cleaner.

Applications include:

- All fast-moving mobile equipment such as trucks, buses and recreational vehicles.

Features and Benefits

- Removes up to 80% of impurities from intake air before the air enters the filter elements.
- Compact, low-profile design.
- The bottom-intake air entry design eliminates the opportunity for water intrusion during high speed and stationary operation.
- Easy to install. Three plastic outlet reduction sleeves are provided with each assembly.

Ordering and Specification

Model	Airflow Range	Horsepower Range	Weight	Max Length	Max Diameter	Outlet Size
AFSF4	766 to 1059 (28.0 to 43.0 m3/min)	300 to 400 HP (239 to 335 KW)	2.40 lbs (1.10 kg)	6.06" (232 mm)	18.11" (385 mm)	7-6.75-6.5-6.25" (178-171-165-159 mm)
AFSF6	988 to 1517 (28.0 to 43.0 m3/min)	320 to 450 HP (239 to 335 KW)	78.65 lbs (35.70 kg)	15.15" (385 mm)	18.11" (385 mm)	5.25" (133 mm)
AFSF8	988 to 1517 (28.0 to 43.0 m3/min)	320 to 450 HP (239 to 335 KW)	78.65 lbs (35.70 kg)	15.15" (385 mm)	18.11" (385 mm)	5.25" (133 mm)
AFSF12	988 to 1517 (28.0 to 43.0 m3/min)	320 to 450 HP (239 to 335 KW)	78.65 lbs (35.70 kg)	15.15" (385 mm)	18.11" (385 mm)	5.25" (133 mm)
AFSF15	988 to 1517 (28.0 to 43.0 m3/min)	320 to 450 HP (239 to 335 KW)	78.65 lbs (35.70 kg)	15.15" (385 mm)	18.11" (385 mm)	5.25" (133 mm)
AFSF18	988 to 1517 (28.0 to 43.0 m3/min)	320 to 450 HP (239 to 335 KW)	78.65 lbs (35.70 kg)	15.15" (385 mm)	18.11" (385 mm)	5.25" (133 mm)
AFSF20	988 to 1517 (28.0 to 43.0 m3/min)	320 to 450 HP (239 to 335 KW)	78.65 lbs (35.70 kg)	15.15" (385 mm)	18.11" (385 mm)	5.25" (133 mm)
AFSF21	988 to 1517 (28.0 to 43.0 m3/min)	320 to 450 HP (239 to 335 KW)	78.65 lbs (35.70 kg)	15.15" (385 mm)	18.11" (385 mm)	5.25" (133 mm)
AFSF310	988 to 1517 (28.0 to 43.0 m3/min)	320 to 450 HP (239 to 335 KW)	78.65 lbs (35.70 kg)	15.15" (385 mm)	18.11" (385 mm)	5.25" (133 mm)
AFSF430	988 to 1517 (28.0 to 43.0 m3/min)	320 to 450 HP (239 to 335 KW)	78.65 lbs (35.70 kg)	15.15" (385 mm)	18.11" (385 mm)	5.25" (133 mm)
AFSF310	988 to 1517 (28.0 to 43.0 m3/min)	320 to 450 HP (239 to 335 KW)	78.65 lbs (35.70 kg)	15.15" (385 mm)	18.11" (385 mm)	5.25" (133 mm)
AFSF430	988 to 1517 (28.0 to 43.0 m3/min)	320 to 450 HP (239 to 335 KW)	78.65 lbs (35.70 kg)	15.15" (385 mm)	18.11" (385 mm)	5.25" (133 mm)

Heavy Duty On-Highway Pre-Cleaners

For Under Hood Applications

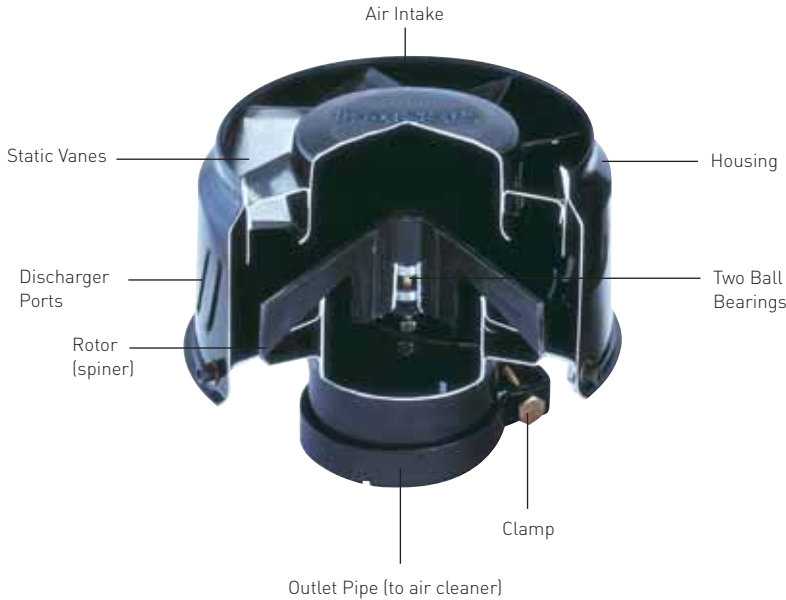

How they work

Racor Under Hood Engine Air Pre-Cleaners can be remote mounted or attached directly to the air cleaner eliminating the need for an external air intake.

- No exterior vehicle modification for intake air.
- High air flow, low differential design.



Ordering and Specification

Model	Airflow Range	Horsepower Range	Weight	Max Length	Max Diameter	Outlet Size
AFSF4	766 to 1059 (28.0 to 43.0 m3/min)	300 to 400 HP (239 to 335 KW)	2.40 lbs (1.10 kg)	6.06" (232 mm)	18.11" (385 mm)	7-6.75-6.5-6.25" (178-171-165-159 mm)
AFSF6	988 to 1517 (28.0 to 43.0 m3/min)	320 to 450 HP (239 to 335 KW)	78.65 lbs (35.70 kg)	15.15" (385 mm)	18.11" (385 mm)	5.25" (133 mm)
AFSF8	988 to 1517 (28.0 to 43.0 m3/min)	320 to 450 HP (239 to 335 KW)	78.65 lbs (35.70 kg)	15.15" (385 mm)	18.11" (385 mm)	5.25" (133 mm)
AFSF12	988 to 1517 (28.0 to 43.0 m3/min)	320 to 450 HP (239 to 335 KW)	78.65 lbs (35.70 kg)	15.15" (385 mm)	18.11" (385 mm)	5.25" (133 mm)
AFSF15	988 to 1517 (28.0 to 43.0 m3/min)	320 to 450 HP (239 to 335 KW)	78.65 lbs (35.70 kg)	15.15" (385 mm)	18.11" (385 mm)	5.25" (133 mm)
AFSF18	988 to 1517 (28.0 to 43.0 m3/min)	320 to 450 HP (239 to 335 KW)	78.65 lbs (35.70 kg)	15.15" (385 mm)	18.11" (385 mm)	5.25" (133 mm)
AFSF20	988 to 1517 (28.0 to 43.0 m3/min)	320 to 450 HP (239 to 335 KW)	78.65 lbs (35.70 kg)	15.15" (385 mm)	18.11" (385 mm)	5.25" (133 mm)
AFSF21	988 to 1517 (28.0 to 43.0 m3/min)	320 to 450 HP (239 to 335 KW)	78.65 lbs (35.70 kg)	15.15" (385 mm)	18.11" (385 mm)	5.25" (133 mm)
AFSF310	988 to 1517 (28.0 to 43.0 m3/min)	320 to 450 HP (239 to 335 KW)	78.65 lbs (35.70 kg)	15.15" (385 mm)	18.11" (385 mm)	5.25" (133 mm)
AFSF430	988 to 1517 (28.0 to 43.0 m3/min)	320 to 450 HP (239 to 335 KW)	78.65 lbs (35.70 kg)	15.15" (385 mm)	18.11" (385 mm)	5.25" (133 mm)
AFSF310	988 to 1517 (28.0 to 43.0 m3/min)	320 to 450 HP (239 to 335 KW)	78.65 lbs (35.70 kg)	15.15" (385 mm)	18.11" (385 mm)	5.25" (133 mm)
AFSF310	988 to 1517 (28.0 to 43.0 m3/min)	320 to 450 HP (239 to 335 KW)	78.65 lbs (35.70 kg)	15.15" (385 mm)	18.11" (385 mm)	5.25" (133 mm)
AFSF430	988 to 1517 (28.0 to 43.0 m3/min)	320 to 450 HP (239 to 335 KW)	78.65 lbs (35.70 kg)	15.15" (385 mm)	18.11" (385 mm)	5.25" (133 mm)

Heavy Duty Off-Highway and Industrial Air Pre-Cleaners

For Agriculture, Construction and Stationary Applications

Applications

Racor Engine Air Pre-Cleaners are designed to be mounted on or connected to the air filter intake of a gasoline or diesel engine air cleaner.

Their applications include all slow-moving and industrial equipment such as agricultural machinery; earth moving, construction and mining equipment; pumping plants; generator sets; material handling equipment; snow removal equipment and street sweepers.



How they work

Racor Engine Air Pre-Cleaners are usually installed in place of the rain cap, dust bowl, or aspirated pre-cleaner (exhaust system). In some applications, they can be mounted directly to the air cleaner.

Air enters the system through a pre-screen that removes large debris. It then flows through static vanes causing the air to spin. As the air spins, centrifugal force separates dust, dirt, insects, rain and snow from the air stream. The swirling air drives a high velocity rotor that acts as a blower evacuating contaminants through special discharge ports at the bottom or in the side of the unit. Only purified air flows to the air filter elements.



Ordering and Specification

Model	Airflow Range	Horsepower Range	Weight	Max Length	Max Diameter	Outlet Size
AFSF4	766 to 1059 (28.0 to 43.0 m3/min)	300 to 400 HP (239 to 335 KW)	2.40 lbs (1.10 kg)	6.06" (232 mm)	18.11" (385 mm)	7-6.75-6.5-6.25" (178-171-165-159 mm)
AFSF6	988 to 1517 (28.0 to 43.0 m3/min)	320 to 450 HP (239 to 335 KW)	78.65 lbs (35.70 kg)	15.15" (385 mm)	18.11" (385 mm)	5.25" (133 mm)
AFSF8	988 to 1517 (28.0 to 43.0 m3/min)	320 to 450 HP (239 to 335 KW)	78.65 lbs (35.70 kg)	15.15" (385 mm)	18.11" (385 mm)	5.25" (133 mm)
AFSF12	988 to 1517 (28.0 to 43.0 m3/min)	320 to 450 HP (239 to 335 KW)	78.65 lbs (35.70 kg)	15.15" (385 mm)	18.11" (385 mm)	5.25" (133 mm)
AFSF15	988 to 1517 (28.0 to 43.0 m3/min)	320 to 450 HP (239 to 335 KW)	78.65 lbs (35.70 kg)	15.15" (385 mm)	18.11" (385 mm)	5.25" (133 mm)
AFSF18	988 to 1517 (28.0 to 43.0 m3/min)	320 to 450 HP (239 to 335 KW)	78.65 lbs (35.70 kg)	15.15" (385 mm)	18.11" (385 mm)	5.25" (133 mm)
AFSF20	988 to 1517 (28.0 to 43.0 m3/min)	320 to 450 HP (239 to 335 KW)	78.65 lbs (35.70 kg)	15.15" (385 mm)	18.11" (385 mm)	5.25" (133 mm)
AFSF21	988 to 1517 (28.0 to 43.0 m3/min)	320 to 450 HP (239 to 335 KW)	78.65 lbs (35.70 kg)	15.15" (385 mm)	18.11" (385 mm)	5.25" (133 mm)
AFSF310	988 to 1517 (28.0 to 43.0 m3/min)	320 to 450 HP (239 to 335 KW)	78.65 lbs (35.70 kg)	15.15" (385 mm)	18.11" (385 mm)	5.25" (133 mm)
AFSF430	988 to 1517 (28.0 to 43.0 m3/min)	320 to 450 HP (239 to 335 KW)	78.65 lbs (35.70 kg)	15.15" (385 mm)	18.11" (385 mm)	5.25" (133 mm)
AFSF310	988 to 1517 (28.0 to 43.0 m3/min)	320 to 450 HP (239 to 335 KW)	78.65 lbs (35.70 kg)	15.15" (385 mm)	18.11" (385 mm)	5.25" (133 mm)
AFSF430	988 to 1517 (28.0 to 43.0 m3/min)	320 to 450 HP (239 to 335 KW)	78.65 lbs (35.70 kg)	15.15" (385 mm)	18.11" (385 mm)	5.25" (133 mm)



Filter Service Indicator

“Filter Minder” Service Indicator is a precision Airflow Restriction Gauge designed to take the guesswork out of air cleaner element replacement. Its operation is simple and virtually foolproof.

As dirt captured by the filter cartridge gradually builds up, the system pressure drop increases and is indicated by the Filter Minder on an easy-to-read scale.

The indicator locks up at the point of maximum restriction so readings can be taken with or without the engine running. When the desired change-out point is reached and the filter cartridge is easily reset by simply pushing the button at the bottom of the unit.



This indicator works equally well on both gasoline and diesel equipment. The Service indicator lets you know exactly when to replace filter elements. It reduces unnecessary labor and element costs by avoiding premature replacement. It permits you to maximize air filter element life.

Economical – Saving one filter element change-out can more than cover the cost of the Service Indicator. It’s a small price for a potentially large gain year after year.

Standard Filter Monitor Part No.s

Part No.	Range (in. water vac.)	Description
400033015 ^A	8-15	Direct Mount
071338002	11	24
071338003	13.5	24
071338004	13.5	18
071338005	13.5	15
071338006	13.5	24

^A Four tube model is special order only.

^B Indicates two moisture separator panels and two filter

Filter Monitor / Single Latching Position

Part Number	Range (in. water vac.)
500198020	20
500198025	25

Accessories

Part No.	Description
400034000	90° fitting [Adapts to straight fitting]

The Engine Air Intake Filter Designed to Protect the

The **ECO III** is Racor's newest filter model, designed specifically to be the most versatile filter on the market, allowing for multiple inlet/outlet angle positions, left or right hand element removal and outlet configurations, with CCV and gauge connections built in. Designed for 250-500HP engines the ECO III's versatility makes it ideally suited for truck, bus and coach applications.

ECO III in a typical Closed Air Filtration System Configuration



John - can you please let me know what you would like to include on this ECOIII spread?

Engine

John - can you please let me know what you would like to include on this ECOIII spread?



Part No.	Description
Housing	
500250012	Housing, Base with Secondary
500250012	Housing, Base without Secondary
Service Elements	
500250012	Primary Element
500250012	Safety Element
Replacement Parts	
500250012	Base
500250012	Outlet Pan
500250012	Clip (8 per package)

For additional information regarding custom manufacturing and ECO III configurations for larger horsepower ratings, please contact Racor Division.

Closed Crank Case Ventilation Systems

The problem – open and unfiltered engine crankcase breathers, allow oil and soot laden aerosol mist to enter the atmosphere from the crankcase.

Environmental concerns and EPA and European legislation bans the emission of open and untreated crankcase gases into the atmosphere. To reduce total engine emissions, it is becoming necessary to close the crankcase breather system, by routing these gases back into the air intake system.

Crankcase blowby is produced when combustion gases under high pressure are blown past the piston rings into the crankcase. As these blow by gases pass through the crankcase, they become contaminated with oil mist.

Racor's crankcase ventilation system removes these contaminations. The exhaust can then be allowed to be vented in the atmosphere.

For applications requiring more stringent emissions requirements, a closed crankcase filter is recommended.

In this application, the exhaust from the crankcase filter is routed to the inlet side of the turbo. A regulator in the crankcase filter controls the vacuum in the crankcase to ensure proper operation.

Pictures below:
 (bottom right) Cummins QSM11 marine engine with CCV cutaway.
 (below) Caterpillar 3196 marine engine with Racor CCV/AF System.

- In closed environments like generator set and marine engine rooms, damage to surrounding equipment such as radiators and electronic control panels can cause hazardous conditions, down time and expensive maintenance.
- Oil mist will coat and contaminate the aftercooler and other engine components. This coating reduces engine cooling capacity, causes a degradation of engine performance and reliability over time, and shortens the useful service life of the engine components.
- The engine intake inhales contaminated gasses, clogging air filter systems and damaging turbo-charger components. It is imperative that oil mist be removed from the crankcase emissions prior to introduction into the engine air intake in closed breather systems.



A modern diesel engine schematic

A schematic indicating air intake filtration, crankcase ventilation and water separation and fuel filtration in a modern diesel engine.

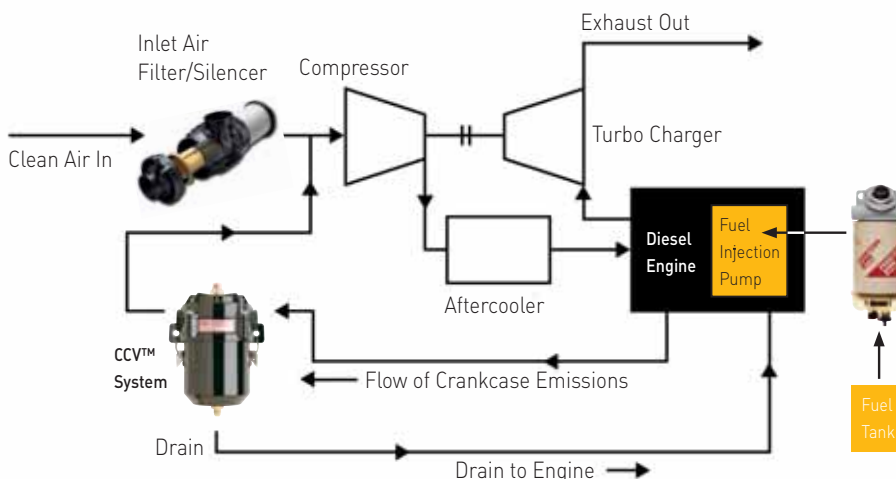



Racor CCV™ Systems

In a robust, compact package, the patented Racor CCV closed crankcase ventilation filter systems provide superior oil coalescence and crankcase pressure control under the most severe conditions.

The only routine maintenance required for the Racor Crankcase Ventilation Filter System is filter replacement. Typical service life of the high performance filter in diesel applications is 750 hours. Some variations in service life occur depending on load profile, engine wear condition, flow and aerosol mass concentration of crankcase emissions, and soot concentration.

How to Select the Racor CCV Assembly: Racor CCV application is determined by crankcase flow in CFM. CFM on new engines is low but as the engine wears on, the CFM increases. Select the correct Racor CCV model by dividing the engine horsepower output by 40.

Single CCV units are designed to handle various crankcase flow rates up to 40 CFM. Traditionally, the crankcase flow rate can be calculated as follows: Rated horsepower \div 40 = cubic feet per minute (CFM). This formula can only be used as a guide since recent improvements in piston design have produced engines with higher horsepower and lower blow-by flow rates. The blow-by flow rate of a worn engine, at time of overhaul, is generally double the flow rate when the engine is new. The flow rate of a worn engine is factored into the formula. Note: Specify left or right hand inlet when ordering.

Example:

CAT 3116-260HP / 40
= 6.5 CFM, select CCV4500

CAT 3406-525HP / 40
= 13.13 CFM, select CCV6000

Unique crankcase pressure regulator with integral bypass valve that minimizes variation in crankcase pressure. Excessive variation in crankcase pressure can damage seals, cause loss of oil and other problems

Pop-up style indicator that alerts of a bypass condition and the need for a filter change

High efficiency oil separation to 0.3 μ (microns)

Durable glass-filled nylon components

Replaceable high-performance filter with depth-loading, micro-glass fiber coalescing media

Maximum continuous operating temperature, -40°F to +240°F (-40°C to 116°C)



Left or right hand inlet/outlet options

Stainless steel latches for tool-less element change

Extended filter service interval from the Vaporbloc™ element

Steel with epoxy powder coating

Drain check valve allows collected oil to be returned to the crankcase. This eliminates frequent draining and significantly reduces oil consumption

Closed Crank Case Ventilation Systems



	CCV1500	CCV3500	CCV4500	CCV6000	CCV8000
Height	6.0" / 152 mm	6.0" / 152 mm	6.25" / 152.0 mm	6.25" / 152.0 mm	6.25" / 152.0 mm
Max. opening width (incl.clamps & brackets)	6.0" / 152 mm	6.0" / 152 mm	6.25" / 152.0 mm	6.25" / 152.0 mm	6.25" / 152.0 mm
Depth	6.0" / 152 mm	6.0" / 152 mm	6.25" / 152.0 mm	6.25" / 152.0 mm	6.25" / 152.0 mm
Weight	6.0" / 152 mm	6.0" / 152 mm	6.25" / 152.0 mm	6.25" / 152.0 mm	6.25" / 152.0 mm
Filter Removal Clearance	6.0" / 152 mm	6.0" / 152 mm	6.25" / 152.0 mm	6.25" / 152.0 mm	6.25" / 152.0 mm
Replacement element/media density/low	6.0" / 152 mm	6.0" / 152 mm	6.25" / 152.0 mm	6.25" / 152.0 mm	6.25" / 152.0 mm
Replacement element/media density/medium	6.0" / 152 mm	6.0" / 152 mm	6.25" / 152.0 mm	6.25" / 152.0 mm	6.25" / 152.0 mm
Replacement element/media density/high	6.0" / 152 mm	6.0" / 152 mm	6.25" / 152.0 mm	6.25" / 152.0 mm	6.25" / 152.0 mm
Housing Material	6.0" / 152 mm	6.0" / 152 mm	6.25" / 152.0 mm	6.25" / 152.0 mm	6.25" / 152.0 mm
	6.0" / 152 mm	6.0" / 152 mm	6.25" / 152.0 mm	6.25" / 152.0 mm	6.25" / 152.0 mm
	6.0" / 152 mm	6.0" / 152 mm	6.25" / 152.0 mm	6.25" / 152.0 mm	6.25" / 152.0 mm
	6.0" / 152 mm	6.0" / 152 mm	6.25" / 152.0 mm	6.25" / 152.0 mm	6.25" / 152.0 mm
Inlet & outlet thread size	6.0" / 152 mm	6.0" / 152 mm	6.25" / 152.0 mm	6.25" / 152.0 mm	6.25" / 152.0 mm
Max. cubic feet per minute	6.0" / 152 mm	6.0" / 152 mm	6.25" / 152.0 mm	6.25" / 152.0 mm	6.25" / 152.0 mm
Crankcase pressure regulator	6.0" / 152 mm	6.0" / 152 mm	6.25" / 152.0 mm	6.25" / 152.0 mm	6.25" / 152.0 mm
Bypass/change indicator	6.0" / 152 mm	6.0" / 152 mm	6.25" / 152.0 mm	6.25" / 152.0 mm	6.25" / 152.0 mm
Engine block check valve return fitting	6.0" / 152 mm	6.0" / 152 mm	6.25" / 152.0 mm	6.25" / 152.0 mm	6.25" / 152.0 mm
Swivel Fitting (Qty.)	6.0" / 152 mm	6.0" / 152 mm	6.25" / 152.0 mm	6.25" / 152.0 mm	6.25" / 152.0 mm
Oil drain hose I.D.	6.0" / 152 mm	6.0" / 152 mm	6.25" / 152.0 mm	6.25" / 152.0 mm	6.25" / 152.0 mm

Additional details are available in technical manual #55021.

* Units can be manifolded to handle higher flow rates.

Crankvent CV820 and CV1000 Systems trap crankcase blow-by and recycle engine oil through a high performance, open-cell foam filter. They help to decrease costs for maintaining air filters and keeping engine rooms clean. These units are typically used as an "open" system for non-turbocharged engines.



Part No.	CV820	CV1000 ²
Filter removal clearance	Up to 350 HP (75-260 KW) ¹	350-600 HP (260-450 KW) ¹
Filter removal clearance	Up to 350 HP (75-260 KW) ¹	350-600 HP (260-450 KW) ¹
Filter removal clearance	Up to 350 HP (75-260 KW) ¹	350-600 HP (260-450 KW) ¹
Filter removal clearance	Up to 350 HP (75-260 KW) ¹	350-600 HP (260-450 KW) ¹
Filter removal clearance	Up to 350 HP (75-260 KW) ¹	350-600 HP (260-450 KW) ¹
Filter removal clearance	Up to 350 HP (75-260 KW) ¹	350-600 HP (260-450 KW) ¹
Filter removal clearance	Up to 350 HP (75-260 KW) ¹	350-600 HP (260-450 KW) ¹
Filter removal clearance	Up to 350 HP (75-260 KW) ¹	350-600 HP (260-450 KW) ¹
Filter removal clearance	Up to 350 HP (75-260 KW) ¹	350-600 HP (260-450 KW) ¹
Filter removal clearance	Up to 350 HP (75-260 KW) ¹	350-600 HP (260-450 KW) ¹

For use on naturally aspirated engines. (1) Use of two or more filters per engine allows higher flow. (2) The Crankvent® CV1000 must be used in two cycle engines with air box drain applications. Additional details are available in technical manual #7503 or please consult Racor.

Open System Crankcase Filtration

High efficiency, high capacity open cell foam filter



A unique baffle design disperses gases throughout the full length of the media – improving efficiency and release of oil into the reservoir – maintaining a low pressure drop throughout an extended filter life. Reduces NOx and hydrocarbon emissions by lowering combustion temperatures (Closed systems only)

Specially-compounded, long-lasting seals

Oil reservoir collects filtered contaminants

Integral drain/check valve allows for periodic disposal of collected oil. For maintenance-free operation, valve can be plumbed directly to the oil pan

Marine Air Filter / Silencers



- Reduces noise up to 10 dba
- Can integrate Racor CCV systems
- Corrosion resistant
- Cleanable air filter
- No tools needed for serving
- Compact design l panels can cause hazardous conditions, down time and expensive maintenance.

Marine Air Filter Assembly

In order to determine the correct marine air filter application, you will need to know the marine air filter rating (AFR). You will need to provide the hose connection to turbo. Choose the correct marine air filter application per the following guideline:

Verify that the marine air filter dimensions will fit into your engine room.

4 cycle engines: $AFR = HP \times 2.0$
 2 cycle engines: $AFR = HP \times 2.5$

Note:

If AFR is close to maximum capacity of the marine air filter as listed below, use the next size larger.

Example:

DDC 12V92TA DDEC (2 cycle – twin turbo):
 $826 \text{ hp} \times 2.5 = 1032.5 \text{ AFR per turbo} =$
 (2) AF M501012

$1110 \text{ hp} \times 2.5 = 1387.5 \text{ AFR per turbo} =$
 (2) AF M601212

CAT 3196 (4 cycle - twin turbo):
 $660 \text{ hp} \times 2.0 = 1320.0 \text{ AFR} =$
 (1) AF M601212

In addition, note the dimensions of the marine air filter outlets and the Racor CCV connector barb outside diameter from the chart in the Marine Air Filter Kit installation Section to ensure the correct installation for your engine. However, the marine air filters typically correspond with the following CCV Models (see chart on right).

The engine crankcase breather

is connected to the inlet of the Racor CCV assembly. The CCV outlet is connected to the engine's combustion air inlet via an air intake connector where filtered blow-by gas is recycled through the combustion process. Oil collected in the CCV sump is returned to the crankcase through a hose and a drain check valve.

The Racor marine air filter/silencer

removes contaminants introduced into the air from both outside and inside the vessel. Sand, salt, carpet fibers and other contaminants are trapped in the oil-impregnated filter media. Turbo noise is reduced by the unique design of the air filter/silencer housing. An integral hose connection on the housing routes the clean blow-by from the CCV back into the engine.



Marine Air Filter	CCV Model
AF M408512	CCV4500
AF M501012	CCV6000
AF M601212	CCV8000

	AF M408512	AF M501012	AF M601212
Max. Air Flow*	800 cfm / 377.6 l/s	1200 cfm / 566.4 l/s	1200 cfm / 566.4 l/s
Max. Air Flow*	800 cfm / 377.6 l/s	1200 cfm / 566.4 l/s	1200 cfm / 566.4 l/s
Max. Air Flow*	800 cfm / 377.6 l/s	1200 cfm / 566.4 l/s	1200 cfm / 566.4 l/s
Max. Air Flow*	800 cfm / 377.6 l/s	1200 cfm / 566.4 l/s	1200 cfm / 566.4 l/s
Max. Air Flow*	800 cfm / 377.6 l/s	1200 cfm / 566.4 l/s	1200 cfm / 566.4 l/s
Max. Air Flow*	800 cfm / 377.6 l/s	1200 cfm / 566.4 l/s	1200 cfm / 566.4 l/s
Max. Air Flow*	800 cfm / 377.6 l/s	1200 cfm / 566.4 l/s	1200 cfm / 566.4 l/s
Max. Air Flow*	800 cfm / 377.6 l/s	1200 cfm / 566.4 l/s	1200 cfm / 566.4 l/s
Max. Air Flow*	800 cfm / 377.6 l/s	1200 cfm / 566.4 l/s	1200 cfm / 566.4 l/s
Max. Air Flow*	800 cfm / 377.6 l/s	1200 cfm / 566.4 l/s	1200 cfm / 566.4 l/s

Operating Temperature

Values given are cubic feet per minute (cfm) and liters per second (l/s).



Marine Air Filter / Silencer (AF) System

CV/CCV Accessories

Select a Fitting/Hose Kit:

Fitting / Hose Kits come with both fittings and enough hose for the inlet and outlet sides of the Racor CCV assembly. Racor CCV filter units require straight thread o-ring x hose barb fittings available only at Racor. In order to determine the correct application, you need to know the quantity and the outside diameter of engine breather(s) hose connection. Fitting/Hose Kits are available in various sizes and configurations. Consult factory or Racor.com.

Optional Tap Sleeves

CCV30100, CCV40100, CCV50125, CCV50125



Hump Hose Fittings

These are designed to be used with existing air cleaner to turbo rubber adapters.

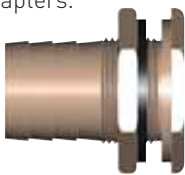

Part Number	Hose
CCV55113	1*
CCV55114	1 1/4"
CCV55115	1 1/2"

FIG. 3

Air Filter Cleaning Kit

To be used for washing and re-oiling Racor cleanable air filters. Part Number: AFM82006



Air Filter Accessories

Low Resistance Flexible Air Inlet Fitting and Clamps

Rubber elbows, adapters and clamps provide positive sealing, minimal airflow restriction and easy servicing.

Flexible air inlet fittings are made of high quality EPDM rubber, and provide minimum airflow restriction between the air cleaner and engine air inlet. Their flexibility simplifies both installation and service. Stainless steel adjustable clamps assure a positive seal and ease of service.



New Pic here?
if so please supply

Cabin Air Filters

Presently, 40% of all vehicles in use have a cabin air filter installed. These filters are used to remove dust, pollen, mold spores, engine exhaust and other gases from the cabin air. The filter should be changed out every 15,000 miles. By servicing the filter, the heater and evaporator will be protected from corrosion and the air in the cabin compartment will be more healthy for the occupants.

Racor now offers cabin air filters for select replacement applications.

Call Racor today to see if your cabin air filter is available.



New Pic here?
if so please supply



Reducer Coupling w/Fitting

Part Number	A	B	E	T	U	V	W
015094047	7.00	5.00	7.00	0.25	1.83	.63	1/8
015094047	7.00	5.00	7.00	0.25	1.83	.63	1/8
015094047	7.00	5.00	7.00	0.25	1.83	.63	1/8
015094047	7.00	5.00	7.00	0.25	1.83	.63	1/8
015094047	7.00	5.00	7.00	0.25	1.83	.63	1/8

Cobra 90° Elbow (Special)

Part Number	A	B	C	D	E	F	T	U
015094047	7.00	5.00	7.00	0.25	1.83	.63	1/8	1.93
015094047	7.00	5.00	7.00	0.25	1.83	.63	1/8	2.50
015094047	7.00	5.00	7.00	0.25	1.83	.63	1/8	5.00

Cobra 90° Elbow

Part Number	A	C	D	E	F	R	T	U
015094047	7.00	5.00	7.00	0.25	1.83	.63	1/8	2.69
015094047	2.75	2.40	0.25					
015094047	2.75	2.40	0.25					

Cobra 90° Elbow (Special)

Part Number	A	B	C	D	E	F	R	T	U
015094047	2.75	2.40	0.25						
015094047	2.75	2.40	0.25						

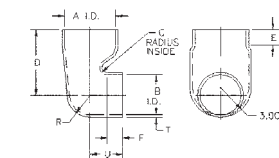
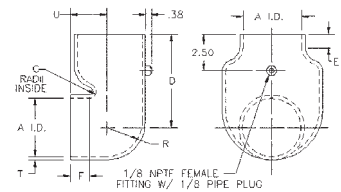
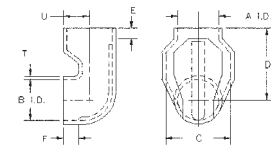
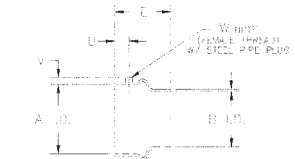

More from Parker Racor

Hydraulic

Parker Filtration's global reputation as a reliable supplier of superior hydraulic and lubrication filtration products, fluid power products and fluid condition monitoring equipment, is the result of a focused and integrated development and manufacturing system. A range of products that cover many markets and most applications.

Hydrocarbon

Hydrocarbon filter vessels and elements represent an important and fast developing part of the Parker Racor range. Installation applications include aviation fuel trucks, diesel fuel dispensing systems; marine fuel docks, bulk fuel storage and garage pump dispensing systems. Racor quality elements offer customers finer filtration, cleaner, drier hydrocarbon products and extended element change intervals.

Marine

It's easy to see why Parker Racor is the most trusted name in marine filtration. Experienced sailors and marine system designers know that a fuel filter failure can stop a craft dead in the water. For nearly four decades, Racor has designed and manufactured diesel fuel filter/water separators that represent the standard in the marine industry.

Fuel & Water

Parker Racor fuel and oil filtration systems provide quality protection for engines operating in any environment, anywhere in the world. Racor's tried and trusted range of Spin-On fuel filter/water separators and the legendary Turbine Series represent, to customers, OEMs and end users alike, the very best in fuel filtration solutions.



Parker Worldwide

AE – UAE, Dhabi
Tel: +971 4 8875600
parker.me@parker.com

AR – Argentina, Buenos Aires
Tel: +54 3327 44 4129

AT – Austria, Wiener Neustadt
Tel: +43 (0)2622 23501-0
parker.austria@parker.com

AT – Eastern Europe, Wiener Neustadt
Tel: +43 (0)2622 23501 970
parker.easteurope@parker.com

AU – Australia, Castle Hill
Tel: +61 (0)2-9634 7777

AZ – Azerbaijan, Baku
Tel: +994 50 2233 458
parker.azerbaijan@parker.com

BE /LX – Belgium, Nivelles
Tel: +32 (0)67 280 900
parker.belgium@parker.com

BR – Brazil, Cachoeirinha RS
Tel: +55 51 3470 9144

BY – Belarus, Minsk
Tel: +375 17 209 9399
parker.belarus@parker.com

CA – Canada, Milton, Ontario
Tel: +1 905 693 3000

CH – Switzerland, Etoy
Tel: +41 (0) 21 821 02 30
parker.switzerland@parker.com

CN – China, Shanghai
Tel: +86 21 5031 2525

CZ – Czech Republic, Klecany
Tel: +420 284 083 111
parker.czechrepublic@parker.com

DE – Germany, Kaarst
Tel: +49 (0)2131 4016 0
parker.germany@parker.com

DK – Denmark, Ballerup
Tel: +45 43 56 04 00
parker.denmark@parker.com

ES – Spain, Madrid
Tel: +34 902 33 00 01
parker.spain@parker.com

FI – Finland, Vantaa
Tel: +358 (0)20 753 2500
parker.finland@parker.com

FR – France, Contamine-s/Arve
Tel: +33 (0)4 50 25 80 25
parker.france@parker.com

GR – Greece, Athens
Tel: +30 210 933 6450
parker.greece@parker.com

HK – Hong Kong
Tel: +852 2428 8008

HU – Hungary, Budapest
Tel: +36 1 220 4155
parker.hungary@parker.com

IE – Ireland, Dublin
Tel: +353 (0)1 466 6370
parker.ireland@parker.com

IN – India, Mumbai
Tel: +91 22 6513 7081-85

IT – Italy, Corsico (MI)
Tel: +39 02 45 19 21
parker.italy@parker.com

JP – Japan, Fujisawa
Tel: +(81) 4 6635 3050

KR – South Korea, Seoul
Tel: +82 2 559 0400

KZ – Kazakhstan, Almaty
Tel: +7 7272 505 800
parker.easteurope@parker.com

LV – Latvia, Riga
Tel: +371 745 2601
parker.latvia@parker.com

MX – Mexico, Apodaca
Tel: +52 81 8156 6000

MY – Malaysia, Subang Jaya
Tel: +60 3 5638 1476

NL – The Netherlands, Oldenzaal
Tel: +31 (0)541 585 000
parker.nl@parker.com

NO – Norway, Ski
Tel: +47 64 91 10 00
parker.norway@parker.com

NZ – New Zealand, Mt Wellington
Tel: +64 9 574 1744

PL – Poland, Warsaw
Tel: +48 (0)22 573 24 00
parker.poland@parker.com

PT – Portugal, Leca da Palmeira
Tel: +351 22 999 7360
parker.portugal@parker.com

RO – Romania, Bucharest
Tel: +40 21 252 1382
parker.romania@parker.com

RU – Russia, Moscow
Tel: +7 495 645-2156
parker.russia@parker.com

SE – Sweden, Spånga
Tel: +46 (0)8 59 79 50 00
parker.sweden@parker.com

SG – Singapore
Tel: +65 6887 6300

SL – Slovenia, Banska Bystrica
Tel: +421 484 162 252
parker.slovenia@parker.com

SL – Slovenia, Novo Mesto
Tel: +386 7 337 6650
parker.slovenia@parker.com

TH – Thailand, Bangkok
Tel: +662 717 8140

TR – Turkey, Istanbul
Tel: +90 216 4997081
parker.turkey@parker.com

TW – Taiwan, Taipei
Tel: +886 2 2298 8987

UA – Ukraine, Kiev
Tel: +380 44 494 2731
parker.ukraine@parker.com

UK – United Kingdom, Warwick
Tel: +44 (0)1926 317 878
parker.uk@parker.com

US – USA, Cleveland
Tel: +1 216 896 3000

VE – Venezuela, Caracas
Tel: +58 212 238 5422

ZA – South Africa, Kempton Park
Tel: +27 (0)11 961 0700
parker.southafrica@parker.com

European Product Information Centre
Free phone: 00 800 27 27 5374
(from AT, BE, CH, CZ, DE, DK, EE, EI, ES, FI, FR, IT, NL, NO, PL, RU, SE, SK, UK, ZA)