

RACOR®

Marine Filtration - Leisure

Brochure FDRB178UK



The most trusted name in engine protection

Racor technology takes the guesswork out of engine protection and Racor manufacturing quality and attention to detail ensures every customer gets the filtration and separation solution they are looking for.

To make product selection easier, Racor's extensive range has been catalogued into four market/ application groups detailed below.

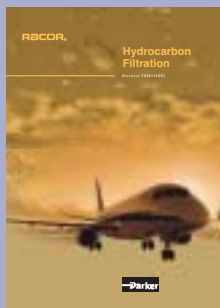

Hydrocarbon Filter Vessels and Elements

From the refinery to the injector, at the terminal and on the forecourt, Racor has a hydrocarbon filter vessel and element solution to your fuel delivery needs.

Ref: FDRB130GB1

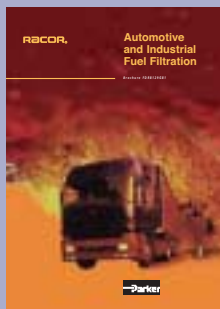

Industrial and Automotive

Everytime you add fuel, you add millions of tiny contaminants...small enough to be invisible, but big enough to destroy injectors, pumps and profitability. Racor's industrial and automotive product range of customer proven spin-on filter/separators, turbine fuel filters and crank case ventilators are the solution.

Ref: FDRB129GB1

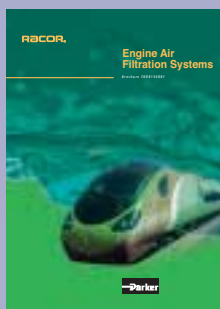

Engine Air Filtration Systems

Fresh air. That's what Racor filtration is all about. Because when engines breathe easier they perform better with more power, more torque and with improved fuel economy. Whatever your application, there's a Racor Air Filtration system that will help you and your engine breathe easy.

Ref: FDRB144GB1

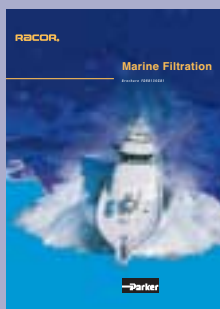

Marine Filtration

Ask a sailor about engine protection. About filtration, about reliability and performance. Whatever they are the master of a superyacht, sailboat, fishing boat or tug, the chances are the one word answer will be the same as it has been for more than three decades...Racor. Marine filtration products trusted across the seven seas.

Ref: FDRB136GB1

For further information Email: filtrationinfo@parker.com

RACOR

The World's Best Filtration starts with the World's Best Engineering.

Parker's technical resources provide the correct filtration technologies that conform to your requirements. That's why thousands of manufacturers and equipment users around the world rely on Parker Filtration products and people.



Hydraulic, Lubrication & Coolant Filtration

High-performance filtration systems for protection of machinery in industrial, mobile and military/marine applications.



Finite and Balston Compressed Air & Gas Filtration

Complete line of compressed air/gas filtration and separation products; coalescing, particulate and adsorption filters in many applications in many industries.



Racor Fuel Conditioning & Filtration

Parker air, fuel and oil filtration systems provide quality protection for engines operating in any environment, anywhere in the world.



Process & Chemical Fluid Filtration

Liquid filtration systems for beverage, chemical and food processing; cosmetic, paint, water treatment; photo-processing; and micro-chip fabrication.



System Contamination Monitoring

On-line dynamic particle analysis, off-line bottle sampling and fluid analysis and measurement of water content polluting the oil in a system.

Parker Filtration's global reputation as a reliable supplier of superior filtration products is the result of a focused and integrated development and manufacturing system.

Parker Filtration consolidates quality filtration products, manufactured for process filtration, air and gas filtration and separation, fuel conditioning and filtration, fluid power products and hydraulic filter products into one broad-based range that covers many markets and most applications, as detailed here.

1975 Cold

1975 Racor pioneers integrated fuel heaters, now standard throughout the industry.

1984 Protection

1984 The Racor Sentinel System shuts down an engine before a major component failure can cause permanent damage. Sentinel remains the preferred all mechanical engine control system.

1987 Standard Equipment

1987 The first Navistar powered Ford E Series and F Series vehicles roll off the production line with the revolutionary, compact and flexible Racor Spin On Series.

1991 The Environment

1991 Along with protecting engines, Racor makes products that protect the environment. Lifeguard is a marine fuel/air separator that prevents fuel from escaping overboard from vent lines during refuelling.

1994 Air

1994 Engines gasping for a breath of fresh air breathe easy with the introduction of synthetic, multi stage Racor "twice the life" air filters.

1996 Plant expansion

1996 In addition to the world class manufacturing facility in Modesto, Racor opens locations in Oklahoma, South Carolina, Brazil, Korea and South Africa.

1998 Additives

1998 For all climates and seasons, Racor Additives are formulated to enhance engine efficiency and performance. It's one more way to run clean.

2001 Global OEM

2001 Racor continues to forge long term relationships with Global OEM companies to produce sound, cost effective engineered solutions to meet specific application requirements.



CONTENTS

Racor Fuelled Up

4 – 5

Turbine Series

6 – 7

Diesel Spin-On Series

8 – 9

Petrol Spin-On Series

10 – 11

P Series & Hydrocarbon Filter Vessels

12 – 13

Fuel / Air Separators & Water Filters

14 – 15

LFS & Bypass Oil Filtration

16 – 17

CCV

18 – 20

Marine Air Filters

21 – 23

Additives

24 – 25

Gauges & Heavy Duty

26 – 27

Over 30 years of innovation, over 30 years of quality...

1969

Diesel Fuel

1969 It all began with a patented, and exceptionally efficient new way to remove water, dirt, rust and algae from diesel fuel.



1983

Technology

1983 Aquabloc® filters debut, and Racor Filter/Separators make another significant leap in filtration efficiency.



1985

Growth

1985 Racor becomes a division of Parker Hannifin Corporation, further strengthening one of the world's most respected brands.



1989

Quality

1989 Racor earns Ford Q1 certification, the first in a series of quality awards from one of the world's leading engine and equipment manufacturers.



1992

Oil

1992 Every bit as vital and every bit as dirty as fuel. The Racor solution is an ingenious one, a cleanable oil filter that puts an end to frequent filter changes and disposal.

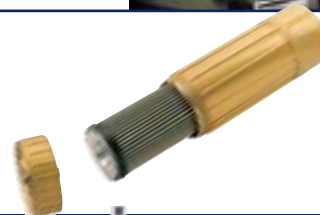

1995

CCV Products

1995 Racor starts cleaning up engine rooms with a crankcase ventilation system that keeps oily blow-by from damaging turbo chargers and other precision components.

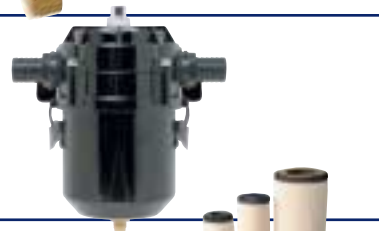

1997

Racor Hydrocarbon

1997 Racor Hydrocarbon Filters and Vessels debut – offering customers flow rates to 1000 gpm and higher.



2000

UK Facility

2000 Having moved out of Morley into a purpose built factory at nearby Dewsbury in 1998 Racor sees significant growth in Europe. 2000 saw the expansion of manufacturing capability to include all spin on series filters, and the establishment of a state-of-the-art design and test, research and development facility.



2002

High performance air filters

2002 Racor purchases Farr opening up opportunities in medium and heavy duty Engine Air applications.

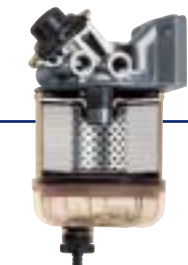

In Europe Morley, West Yorkshire in the UK becomes the centre of excellence in Europe.



Racor on board



It's easy to see why Racor is the most trusted name in Marine Filtration.



Diesel Fuel Filter/
Water Separators

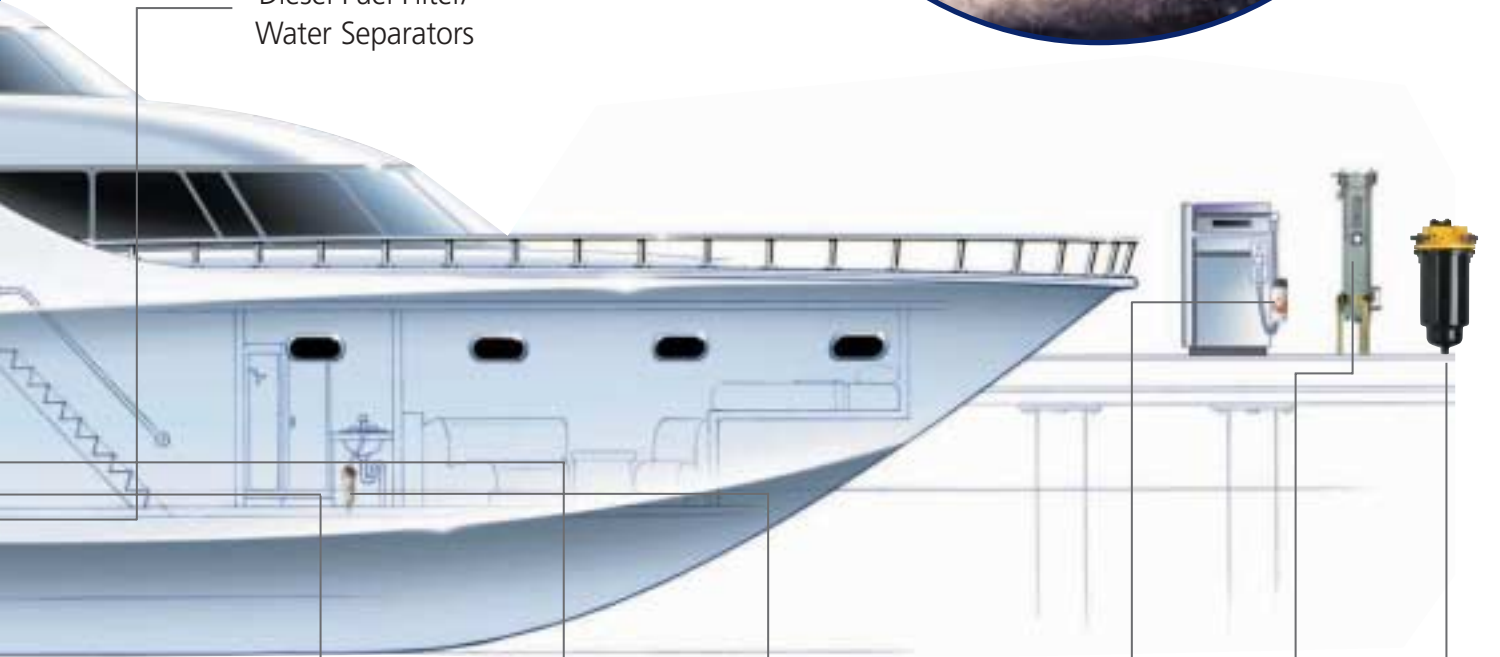

Crankcase
Filtration



Air Filter/
Silencers



Drinking
Water
Filters



Additives



Fuel
Dispensing
Filters



Fuel
Delivery



FBO

Legendary Diesel Fuel Filtration



When engines demand high efficiency, high capacity water separation and fuel filtration, the Turbine Series is the most complete and reliable engine protection you can install. Symbolising Racor's continuing commitment to the science of filtration, the Turbine Series has established its position as the filter/separator often imitated, but never equaled. Models which include an aluminum or stainless steel shield meet ASTM FS1201 certification and are UL-listed, ABS, Veritas, and U.S. Coast Guard accepted. For severe service and gasoline applications, all-metal bowls can be specified.

A single valve on all of the double manifold MAX models isolates one filter/separator for service while the other keeps operating. This way, you keep running while draining contaminants from the collection bowl or changing filter elements.



Order Genuine Aquabloc II Replacement Elements.

Be sure to specify both the size of element and the micron rating.

MODEL	500	900	1000
2 Micron	2010SM-OR	2040SM-OR	2020SM-OR
10 Micron	2010TM-OR	2040TM-OR	2020TM-OR
30 Micron	2010PM-OR	2040PM-OR	2020PM-OR

S = Secondary/Final 2 micron (Brown end cap)
 T = Primary or Secondary/Final 10 micron (Blue end cap)
 P = Primary 30 micron (Red end cap)



For convenience, end-caps are color-coded for easy identification and application – red for 30-micron primary filtration, blue for 10-micron primary or secondary and brown for 2-micron secondary/final filtration.

An internal shut-off valve in the 900 and 1000 series safeguards your engine from inferior will-fit elements.

Aquabloc II media is a blend of high-grade cellulose compounded with engineered fibers and a special chemical treatment. Water won't even cling to the element. Aquabloc II repels it.

With every Aquabloc®II replacement element, you receive a complete seal kit. Racor seals are specially formulated, and tested for endurance.

Besides removing asphaltenes, gums and varnishes, Aquabloc II elements filter tiny particles of dirt and algae from fuel. Aquabloc II elements are rustproof – with polymer end-caps that won't ever corrode.

The Inside Story

How it works

- 1** As fuel enters, it moves past the internal check valve then through the turbine centrifuge where it flows in a spiraling direction, spinning off large particulates and water droplets. Being heavier than fuel, they fall to the bottom of the collection bowl.
- 2** Smaller water droplets bead-up along and on the sides of the internal components and on the surface of the Aquabloc II element. When heavy enough, they too fall into the high-capacity bowl to be drained as needed.
- 3** Besides repelling water and tiny solids, asphaltenes, algae and rust are filtered from fuel by the Aquabloc II element. Because Aquabloc II elements are waterproof, they remain effective longer.

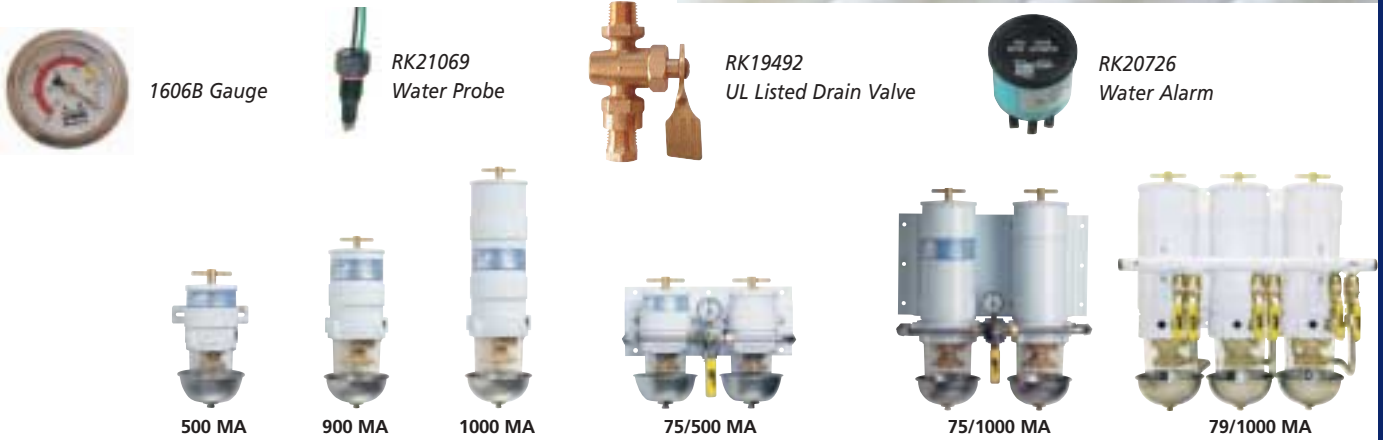
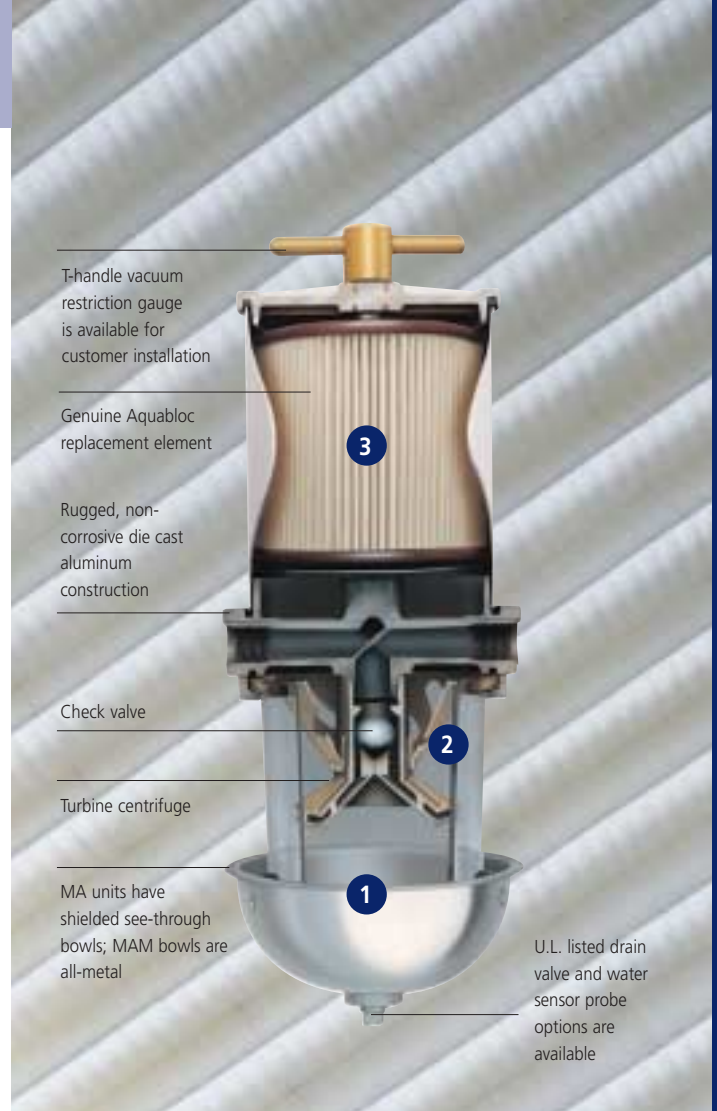

MODEL	500 MA	900 MA	1000 MA	75/500 MAX ¹	75/900 MAX ¹	73/1000 MA ¹	75/1000 MAX ¹	77/1000 MA ^{1,2}	79/1000 MA ¹
Maximum Flow Rate	227 lph 60 gph	341 lph 90 gph	681 lph 180 gph	454 lph 120 gph	681 lph 180 gph	1363 lph 360 gph	681 / 1363 lph 180 / 360 gph	2044 lph 540 gph	1363 / 2044 lph 360 / 540 gph
Height	292 mm / 11.5"	432 mm / 17"	559 mm / 22"	292 mm / 11.5"	432 mm / 17"	559 mm / 22"	559 mm / 22"	559 mm / 22"	559 mm / 22"
Width	147 mm / 5.8"	152 mm / 6"	152 mm / 6"	368 mm / 14.5"	476 mm / 18.75"	432 mm / 17"	476 mm / 18.75"	546 mm / 21.5"	546 mm / 21.5"
Depth	122 mm / 4.8"	178 mm / 7"	178 mm / 7"	241 mm / 9.5"	279 mm / 11"	305 mm / 12"	279 mm / 11"	305 mm / 12"	305 mm / 12"
Weight	2 Kg / 4 lbs	3 Kg / 6 lbs	5 Kg / 10 lbs	7.7 Kg / 17 lbs	10 Kg / 23 lbs	11.8 Kg / 26 lbs	13.6 Kg / 30 lbs	17.7 Kg / 39 lbs	23.6 Kg / 52 lbs
Port Size Std. (Option)	3/4" -16 UNF 14 mm x 1.5	7/8" -14 UNF 22 mm x 1.5	7/8" -14 UNF 22 mm x 1.5	3/4" -16 UNF	7/8" -14 UNF	3/4" NPT	7/8" -14 UNF	1" -11.5 NPT	3/4" NPT
Clean Pressure Drop	0.04 bar 0.61 PSI	0.02 bar 0.34 PSI	0.03 bar 0.49 PSI	0.05 bar 0.70 PSI	0.11 bar 1.7 PSI	0.11 bar 1.7 PSI	0.25 bar 3.7 PSI	0.11 bar 1.7 PSI	0.17 bar 2.5 PSI
Maximum Operating Pres.	1 bar 15 PSI	1 bar 15 PSI	1 bar 15 PSI	1 bar 15 PSI	1 bar 15 PSI	1 bar 15 PSI	1 bar 15 PSI	1 bar 15 PSI	1 bar 15 PSI
Element #	2010	2040	2020	2010	2040	2020	2020	2020	2020
Element Rmvl. Clearance	102 mm / 4"	127 mm / 5"	254 mm / 10"	102 mm / 4"	127 mm / 5"	254 mm / 10"	254 mm / 10"	254 mm / 10"	254 mm / 10"

NOTES: (1) For double or triple manifold models with 1/2" isolation valves, specify MAV. For double manifold models with single isolation valve and standard filter restriction gauge, specify MAX. The engine may be left operating during isolation of either filter. (2) 77/1000 triple manifold without shutoff valve also available. (3) Turbine Series MA units with metal shield are 1" shorter than metal bowl units.

(4) Vacuum installation only. For accurate fuel flow rates consult your engine manual. As a guideline, gph = 0.18 x maximum engine horsepower (diesel only). (5) Filter/separators are available with metric tapped ports. Specify metric ports when ordering. (6) Specify MAM units for gasoline applications.

Racor 'See-Through' Technology takes the guesswork out of engine protection.

- Cost-Effective Visual Inspection
- High Capacity
- Environmentally Friendly
- Easy Upgrades
- Corrosion-Free Construction

Aquabloc media is corrugated, which means more surface area exposed for fuel filtration... and more dirt-holding capacity.

Polymer bowls are virtually indestructible. They won't discolor from exposure to alcohol, additives or UV light – a see-through that stays see-thru. A die cast aluminum bowl is available for most models.

Powerful primer pumps integrated into mounting heads.

Die cast aluminum heads with multiple ports make installation as easy as adding options.

The best gaskets and o-rings available for consistent, sure seals.

Water sensor and vacuum gauges to signal service are valuable options available for most models.

Bowl removal wrench available 22628.

Racor quality in one easy spin

- High capacity, on-engine primary or secondary filtration
- Fits most existing mounting heads
- See-through bowl with water sensor option
- Mounting heads available. Contact Racor or your distributor.

Positive seal self-venting drain eliminates leaks, and speeds service.

Aquabloc®. Waterproof, rustproof, dirtproof.

Racor's genuine Aquabloc filter media is engineered to repel water and remove solid contaminants before they can damage precision engine components. Racor Aquabloc elements are available in different lengths for various flow rates and colour-coded 2, 10 and 30 micron. The lower the micron rating, the finer the filtration. Lower micron ratings should be considered when there is no additional downstream filtration. Ultimately, the micron rating preferred will be a function of fuel quality, operating climates and maintenance schedules.

Filter Adapter

A Filter Adapter Part No. IN CAV turns a CAV cartridge-type unit into a spin-on fuel filter/water separator. The adapter fits directly onto the CAV head. Applications include Perkins, Lister and Ford-Lehman engines. A Racor Engine Spin-on (B32008 or B32016) can then be added. The Racor Engine Spin-on Series features proprietary Aquabloc media and reusable see-through collection bowls.

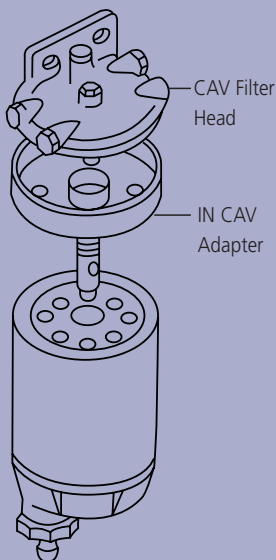

Dual Spin-On Filter/Separators



Dual Spin-On Filter/Separators

With the Racor Models 75/B32016 and 75/B32009, a simple turn of the integral handle puts a clean filter in service when the on-line filter gets dirty so engines can keep operating. Maximum fuel flow is 120 lph (40 gph) and 454 lph (120 gph), respectively, with both filters on-line (or one-half maximum fuel flow with one filter on-line). Three micron ratings can be specified and an optional metal bowl is available for severe service applications.



Note: Element replacement is not possible while the engine is running.

There are important differences among Spin-On Series features which affect performance and applications.



MODEL NO.	110A	120A	230	245	460	490	4120	3150R	3250R
Maximum Flow Rate	57 lph/15 gph DIESEL 133 lph/35 gph GAS	57 lph/15 gph	114 lph/30 gph	170 lph/45 gph	227 lph/60 gph	341 lph/90 gph	454 lph/120 gph	568 lph/150 gph	946 lph/250 gph
Gasoline or Diesel ¹	Both	Both	Diesel	Diesel	Diesel	Diesel	Diesel	Diesel	Diesel
Vacuum Installation	Yes	Yes	Yes	Yes	Yes	Yes	Yes	Yes	Yes
Pressure Installation	Yes	Yes	Yes	Yes	Yes	Yes	Yes	Yes	Yes
Maximum Pressure	7 bar/100 PSI	0.5 bar/7 PSI	2 bar/30 PSI	2 bar/30 PSI	2 bar/30 PSI	2 bar/30 PSI	1 bar/15 PSI	0.5 bar/7 PSI	0.5 bar/7 PSI
Clean Pressure Drop	0.01 bar 0.15 PSI	0.01 bar 0.15 PSI	0.02 bar 0.31 PSI	0.04 bar 0.61 PSI	0.03 bar 0.39 PSI	0.06 bar 0.95 PSI	0.06 bar .85 PSI	0.05 bar .68 PSI	0.07 bar 1.0 PSI
Port Size	1/4" NPT	1/4" NPT	1/4" NPT	1/4" NPT	3/8" NPT	3/8" NPT	3/4" SAE	7/8"-14 SAE	7/8"-14 SAE
Integral Primer Pump ³	No	No	Yes	Yes	Yes	Yes	Yes	No	No
Replacement Element No. ⁴	R11 T	R12 ⁴	R20 ⁴	R25 ⁴	R60 ⁴	R90 ⁴	R120 ⁴	S3238 ⁵	S3207 ⁵
See-Thru Bowl	No	Yes	Yes	Yes	Yes	Yes	Yes	Yes	Yes
Metal Bowl Unit	STD	120RMAM	230RMAM	245RMAM	460MAM	490MAM	4120MAM	N/A	N/A
MAM Element ¹	R11T	R12SUL	R20TUL	R25TUL	S3211TUL	S3201TUL	S3201TUL	N/A	N/A
No. of Ports	4	4	3	3	4	4	4	2	2
Drain Type	Positive Seal	Positive Seal	Positive Seal	Positive Seal	Positive Seal	Positive Seal	Positive Seal	Positive Seal	Positive Seal
Water Sensor Option	No	Yes	Yes	Yes	Yes	Yes	Yes	Yes	Yes
Height	152 mm / 6"	165 mm / 6.5"	229 mm / 9"	267 mm / 10.5"	279 mm / 11"	300 mm / 11.8"	381 mm / 15"	346 mm / 13.63"	438 mm / 17.25"
Width	81 mm / 3.2"	81 mm / 3.2"	102 mm / 4"	102 mm / 4"	114 mm / 4.5"	114 mm / 4.5"	114 mm / 4.5"	127 mm / 5.00"	127 mm / 5.00"
Depth	81 mm / 3.2"	81 mm / 3.2"	102 mm / 4"	102 mm / 4"	121 mm / 4.8"	121 mm / 4.8"	121 mm / 4.8"	140 mm / 5.5"	140 mm / 5.5"
Weight	0.59 kg/1.3 lbs	0.59 kg/1.3 lbs	0.90 kg/2 lbs	1.0 kg/2.2 lbs	1.3 kg/2.7 lbs	1.4 kg/2.9 lbs	1.8 kg/3.9 lbs	1.63 kg/3.6 lbs	2.08 kg/4.6 lbs

NOTES: (1) Use 110A and MAM versions for inspected or commercial vessels.
 (2) Pressure installations are applicable up to the maximum PSI shown.
 (3) Models with integral primer pumps are not recommended for gasoline applications.

(4) Replacement element micron rating can be specified as "S" for 2 micron, "T" for 10 micron, or "P" for 30 micron as a suffix.
 (5) Ten micron only.

The Most Complete Protection on The Water

- Clear contaminate collection bowl for outboards
- Drain valve or plug
- Ten micron Aquabloc® media
- Long life with 98% efficiency
- Corrosion resistant construction
- Metal bowl units for inboard applications

Note: Racor filter/separators will not separate oil from gasoline blended fuel mixtures.



Basic Models	120R-RAC-01	120R-RAC-02	320R-RAC-01	320R-RAC-02	660-RAC-01	660-RAC-02	3120R-RAC-32
Maximum Flow Rate	114 lph / 30 gph	114 lph / 30 gph	340 lph / 60 gph	340 lph / 60 gph	454 lph / 90 gph	227 lph / 90 gph	227 lph / 120 gph
Filter Element No.	S3240	S3240UL	S3227	S3228UL	S3232	S3232UL	S3232UL
Center Threads	M18 x 1.5	M18 x 1.5	1-14	1-14	1-14	1-14	1-14
Head Port Size	1/4-18NPTF	1/4-18NPTF	1/4-18NPTF	1/4-18NPTF	3/8-18NPTF	3/8-18NPTF	1/2-14NPTF(1)
Height	166 mm / 6.5"	153 mm / 6.0"	238 mm / 9.38"	238 mm / 9.38"	280 mm / 11.00"	280 mm / 11.00"	264 mm / 10.38"
Width	81 mm / 3.2"	81 mm / 3.2"	102 mm / 4"	102 mm / 4"	106 mm / 4.2"	106 mm / 4.2"	102 mm / 4"
Depth	81 mm / 3.2"	81 mm / 3.2"	102 mm / 4"	102 mm / 4"	114 mm / 4.5"	114 mm / 4.5"	127 mm / 5"
Weight (dry)	.05 kgs/1.1 lbs	.06 kgs/1.2 lbs.	0.90 kgs/2 lbs	0.90 kgs/2 lbs	1.4 kgs/3 lbs	1.4 kgs/3 lbs	0.90 kgs/2 lbs
Clean Pressure Drop	0.01 bar/0.15 PSI	0.01 bar/0.15 PSI	0.04 bar/0.61 PSI	0.04 bar/0.61 PSI	0.04 bar/0.61 PSI	0.04 bar/0.61 PSI	0.01 bar/0.15 PSI
Max Pressure	0.5 bar/7 PSI	0.5 bar/7 PSI	0.5 bar/7 PSI	0.5 bar/7 PSI	0.5 bar/7 PSI	0.5 bar/7 PSI	0.5 bar/7 PSI
Element Removal/Underbowl	25.4mm / 1"	25.4mm / 1"	25.4mm / 1"	25.4mm / 1"	25.4mm / 1"	25.4mm / 1"	25.4mm / 1"

Operating Temp. -40° C – 124° C / -40° F – 255° F

NOTE:(1) Pressure installations are applicable up to the maximum PSI shown.

Upgrade your existing filter.

Now, owners of inboard or outboard engines can get smoother operation and longer life – all in one easy spin onto existing filter heads. There's a choice of rugged, reusable see-through bowl with self-venting drain, or a metal bowl with drain plug for inboard applications.

Metal bowls are UL-listed and USCG accepted. See-through bowls are recommended for outboard applications only.



Bowl removal wrench Part No. 22628

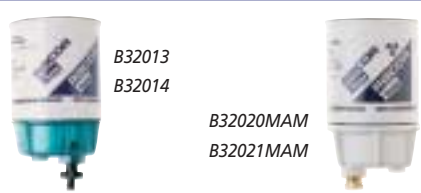

B32013	Replaces Quicksilver. Also fits: Yamaha, Suzuki, SMI, Volvo Penta, Sierra, AquaPower and other filter heads. With see-through bowl. OUTBOARD APPLICATIONS ONLY.
S3213	Replacement Element for B32013. OUTBOARD APPLICATIONS ONLY.
B32014	Replaces OMC. See-through bowl. OUTBOARD APPLICATIONS ONLY.
S3214	Replacement Element for B32014. OUTBOARD APPLICATIONS ONLY.
B32020MAM	Replaces Quicksilver. Also fits: Yamaha, Suzuki, SMI, Volvo Penta, Sierra AquaPower and other filter heads. Metal bowl, INBOARD OR OUTBOARD APPLICATIONS.
S3220UL	Replacement Element for B32020MAM
B32021MAM	Replaces OMC Metal Bowl. UL recognized. INBOARD OR OUTBOARD APPLICATIONS
S3221UL	Replacement Element for B32021MAM

Compact filters available for smaller boats and marine generators.



Part No.	025RAC01	025RAC02	025RAC05	110A
Flow Rate	95 lph/25 gph	95 lph/25 gph	95 lph/25 gph	133 lph/35 gph
Media	250 micron cleanable plastic screen	10 micron Aquabloc filter	10 micron Cellulose filter	10 micron Aquabloc filter
Config	Anodized mounting head w/reusable see-through bowl	Anodized mounting head w/reusable see-through bowl	Stainless steel body w/electrostatic epoxy paint	1/4 npt die-cast mounted mounting head
Dimensions	57mm x 108mm 2.25" x 4.25"	57mm x 108mm 2.25" x 4.25"	120mm x 58mm 4.75" x 2.3"	152mm x 81mm 6" x 3.2"

Upgrade to a Racor

Par <> Fit Element for Separ 2000/10



		Parker Part No.
Separ	01010	PFF5600
Separ	01030	PFF5601
Deutz	03119822	PFF5601
Man	811250 10030	PFF5601

Gasoline Spin-On

Replaces water separators and spin on filters for most inboard, outboard 2 and 4 cycle gasoline engine applications. (Mercury, Yamaha, Suzuki, Honda, Tohatsu) for 1 1/16" threaded heads replaces Mercury 35-604941 and 35-807172.



Fuel Filter Funnel

The Racor Fuel Filter Funnel (RFF) family is a new heavy-duty, fast-flow, filter-in-a-funnel that separates damaging free water and contaminants from gasoline, diesel, heating oil, and kerosene.

The new RFF family of products is capable of removing free water and solids down to .005 inches and allows you to visually inspect the integrity of your fuel supply as you refuel.



In 2.7, 3.9, 5.0 and 15 gallon per minute flow rates.

Caution for Users:

Petroleum products flowing over a plastic surface generate static electricity. Caution should be taken to ensure that the RFF is grounded to reduce static electricity buildup and reduce the chance of explosions or fire. Electrically bond the funnel by using a wire with a metal clip on each end and clamp one to the upper rim of the funnel and the other to the fueling source. For example, the metal gas can or nozzle from the pump.



Integrated Fuel Pump

Durable, 12V DC roller-cell electric fuel pump offers the benefit of an electric, on-demand, priming pump.



Thermostatically controlled PTC-style electric (150-watt) heater facilitates cold weather starting.

High-performance Aquabloc II cartridge-style filter media is environmentally friendly and incinerable.

Removable and reusable contaminant collection bowl with self-venting drain.

Water-in-fuel (WIF) sensor alerts the operator when service is required. Under-dash control module for pump and water sensor operation is included with pump option.



Basic Models	P3	P4	P5
Maximum Flow Rate	30 gph/114 lph	40 gph/170 lph	50 gph/227 lph
Clean Pressure Drop	0.4 psi/2.8 kPa	0.5 psi/3.4 kPa	0.8 psi /5.5 kPa
Max. Pump Output (at 14.4 volts)	40 gph/151 lph	40 gph/151 lph	40 gph/151 lph
Standard Fuel Port Size (SAE J476)	3/8" – 18 npt	3/8" – 18 npt	3/8" – 18 npt
Total Number of Ports Available:	2	2	2
Fuel Inlets	1	1	1
Fuel Outlets	1	1	1
Replacement Elements:			
02 micron	R58060-02	R58095-02	R58039-02
10 micron	R58060-10	R58095-10	R58039-10
30 micron	R58060-30	R58095-30	R58039-30
Minimum Service Clearance	2.5" (28 mm)	2.5" (28 mm)	2.5" (28 mm)
Height	7.7" (196mm)	9.0" (229 mm)	11.5" (292 mm)
Depth	5.2" (132 mm)	5.2" (132 mm)	5.2" (132 mm)
Width	4.8" (122 mm)	4.8" (122 mm)	4.8" (122 mm)
Weight (dry)	3.4 lb (1.5 kg)	3.8 lb (1.7 kg)	4.2 lb (1.9 kg)
Maximum Pump Output Pressure	10 psi (69 kPa)	10 psi (69 kPa)	10 psi (69 kPa)
Features: ¹			
Water Sensor	Standard	Standard	Standard
Heater	Standard	Standard	Standard
Pressure Regulator (10 psi)	Standard	Standard	Standard
Operating Temperature	-40° to +255°F / -40° to +121°C		

Vacuum installations are recommended. ¹ Not for use with gasoline applications.



The patented P Series diesel fuel conditioning module (for vacuum side applications only) was developed for application in any diesel engine fuel injection system. P Series assemblies are available in three sizes and all feature 3/8" NPT fuel ports. This innovative and modular fuel filter/water separator incorporates low-pressure fuel system components into a single package. Supplies clean, dry fuel to the fuel system and serves as a repriming system.

How To Order – The example below illustrates how part numbers are constructed.

P4	2	10
Specify 'P3' for 30 gph, 'P4' for 40 gph or 'P5' for 50 gph	'2' must be in the part number. (It specifies a 12 vdc pump)	Specify micron rating of element '02, '10', or '30'
N	H	
'N' must be in the part number. (It specifies standard 3/8" npt ports)	'H' must be in the part number. (It specifies a 12 vdc, 150 watt heater)	

The Ultimate in High Capacity Filtration and Re-Fuelling

High Capacity and Re-Fueling Vessels

The Racor FBO and RVFS Series filter vessels offer unparalleled efficiency, versatility and an economical, low maintenance solution to many fuel conditioning applications. The vessels will accept Micro-filter pre-filters, Coalescer / Water Separator combinations, Monitor / Absorbers and clay treatment bags.

Used mainly in the diesel re-fuelling industry, these robust vessels can be seen on countless forecourts providing clean, dry, safe fuel to modern TDI, PD, HDI CDI and heavy duty vehicles. Equally these vessels can be used for



kerosene, aviation fuels, heating oils, gasoline and numerous other industrial fluids and fuels.

The Racor FBO Filter Vessel offers an optional mounting bracket for secure installation.



Features

- ASME Code, Section VIII construction, stamped & certified.
- Designed for low pressure drop.
- Designed for easy element changeouts.
- A variety of positive element seal designs are available.
- Welded carbon steel construction is standard. Alternate material types, including stainless steel and aluminum, can be designed and constructed for your requirements.
- A variety of interior and exterior surface coatings are available for your specification.
- Large capacity sumps are incorporated into each design.
- CAD provides fast and accurate custom vessel designs.



RVFS-2

		RVFS-1	RVFS-2	RVFS-3	Micron sizes
Element Options	Silicone-treated				
	Pleated Pre-filters	6" x 14"	6" x 30"	6" x 44"	0.5, 1, 2, 5, 10, 25
	FBC Clay Bags	7" x 18"	7" x 18"	7" x 18"	N/A
	Water Absorbing Elements	6" x 14"	6" x 14"	6" x 14"	1, 5, 10, 25
	OCP Coalescer	8" x 15"	8" x 30"	8" x 44"	1, 2, 5, 10, 25
	Teflon® Separator	4" x 15"	4" x 30"	4" x 44"	Screen

Imperial measurements are industry standard. For additional information, request brochure no. RAC1004GD01 Vessel Filter Element Options Identification and Application Guide.

Vessel Series	806	812	FBO-10	FBO-14	RVFS-1	RVFS-2	RVFS-3
Fuel Ports	1" NPT	1" NPT	1 1/2" NPT	1 1/2" NPT	2" NPT	2" NPT	2" NPT
Max. Flow Rate	1363 lph / 360 gph	2725 lph / 720 gph/	3785 lph / 1000 gph	5680 lph / 1500 gph	189 lpm / 50 gpm/	378 lpm / 100 gpm	568 lpm / 150 gpm
Max. Working Pressure	2 bar/30 PSI	2 bar/30 PSI	10 bar/150 PSI	10 bar/150 PSI	Jet A, AV Gas Flow Rates		
Clean Pressure Drop	0.1bar/1.6 PSI	0.2bar/3.2 PSI	0.3bar/5 PSI	0.3bar/5 PSI	189.3 lpm / 50 gpm	378.5 lpm / 100 gpm	568 lpm / 150 gpm
Temperature Rating	-23 C / +82 C	-23 C / +82 C	-23 C / +115 C	-23 C / +115 C	Diesel Fuel Flow Rates		
	-10 F / +180 F	-10 F / +180 F	-10 F / +180 F	-10 F / +180 F	94.5 lpm / 25 gpm	189 lpm / 50 gpm	283.5 lpm / 75 gpm
Design Pressure					17 bar/245 PSI	17 bar/245 PSI	17 bar/245 PSI
Design Temperature					121 C / 250 F	121 C / 250 F	121 C / 250 F
Height	610 mm / 24"	855 mm / 34"	478 mm / 19"	580 mm / 23"	991 mm / 39"	1295 mm / 51"	1651 mm / 65"
Width	226 mm / 9"	226 mm / 9"	165 mm / 6.5"	165 mm / 6.5"	350 mm / 13.75"	350 mm / 13.75"	350 mm / 13.75"
Depth	226 mm / 9"	226 mm / 9"	155 mm / 6"	155 mm / 6"	343 mm / 13.5"	343 mm / 13.5"	343 mm / 13.5"
Dry Weight	11 kgs / 25 lbs	15 kgs / 33 lbs/	17 kgs / 37 lbs	18.5 kgs / 41 lbs	91 kgs / 200 lbs	113 kgs / 250 lbs	136 kgs / 300 lbs
Collection Bowl Capacity	3.7 L	3.7 L	0.6 L	0.6 L			
Minimum overhead space required for element change	152 mm / 6.0"	305 mm / 12"	n / a	n / a	406 mm / 16"	813 mm / 32"	1194 mm / 47"

806 and 812 vessels available in duplex (73/75) or triplex (79) configurations.

RK 22610 Replacement Element Kit (contains one each of 8021 and 8022 filter elements and a lid gasket; 75812 requires 2 kits; 79812 requires 3 kits)

Eliminate Fuel Vent Overflow During Refuelling

Next time you fill up, watch your fuel vent line. A typical refuelling will send up to a half a gallon or more of fuel spilling overboard. Fuel spillage is not only expensive, it's absolutely deadly to fragile lakes, rivers and waterways. Also in some countries regulations prohibiting the discharge of oils include civil and criminal penalties.

Installed in the fuel tank vent line, the Racor Fuel/Air Separator efficiently separates air from fuel forced into the line. Air is vented, and all fuel is returned to the tank. The Fuel/Air Separator captures fuel normally discharged due to agitation and thermal expansion up to 0.25 BAR (2.4 PSI). It also eliminates damage to expensive striping and labels and protects finishes from fuel stains. The unit is also maintenance free – there's nothing to rust or corrode.

The Racor Fuel/Air Separator fits neatly into your vent line, actually replacing a section of the line. Fittings are included. One fuel/Air separator unit is required for each vent line, and both models fit 5/8" vent lines.



	LG50	LG100
Application	Gasoline	Diesel or Gasoline
Dimensions	45mm D x 150mm L 1.75" D x 6" L	100mm D x 250mm L 4" D x 9.75" L
Max Air Flow	5.6 lps / 12 cfm	8 lps / 17 cfm
Thermal Expansion	0.16 bar / 2.4 PSI	0.16 bar / 2.4 PSI
Vent Line Size ¹	17mm / 5/8"	17mm / 5/8"

NOTES: (1) Adapter fitting is available for larger or smaller vent lines. Order part #RK50033.



Courtesy of Alphagraphics.

Selecting a Racor Water Filter That's Right For You

The same innovative technology that's made Racor the first name in marine engine protection makes Racor Drinking Water Filters a natural addition to your boat. Highly effective against the many contaminants present in on-board water supplies, Racor Drinking Water Filters ensure that you will have clean, fresh water on hand. There are two types of high efficiency Racor Water Filters – Taste and Odor Removal and Sediment Removal. Both models serve a single cold water faucet or water tank inlet and are sure to provide a refreshing improvement in water taste and quality.

- Multiple layers of tightly wound synthetic yarns trap sediment, rust, algae and other microscopic solids.
- Tough, tight-sealing see-through bowl lets you inspect filter effectiveness at a glance.
- Activated charcoal element option for taste and odor removal.



Model No.	Description	Replacement
WFA12-S5	Sediment Removal, 5 micron	WFC-S5
WFA12-S30	Sediment Removal, 30 micron	WFC-S30
WFA12-S60	Sediment Removal, 60 micron	WFC-S60
WFA12-T5	Taste and Odor Removal, 5 micron	WFC-T5

Invest in Your Business and the Environment

Lubrication filter changes, once routine, have become a very messy problem. It begins with the extensive, and expensive, inventory required for various engines and equipment. You can eliminate the entire expensive mess and improve filtration effectiveness at the same time, it's a permanent change – for the better, by changing to Racor Lubrication Filtration Systems.

Direct Spin-On Full Flow Cleanable Series

The Racor Spin-On oil filter threads directly onto virtually all engine lube oil heads.

LFS 700 Series Spin-On Filter Specifications

LFS 700	
Flow Rate	170 lpm / 45 gpm
Maximum Pressure Diff.	.52 bar / 7.5 PSI
Weight	3.1 kg / 6.8 lb
Diameter	11.4 cm / 4.5"
Height Over-All	31 cm / 12.25"
Clearance Required Filter Removal	53.3 cm / 21"
Micron Rating (Nominal) Outer Element	25
Inner Element	10

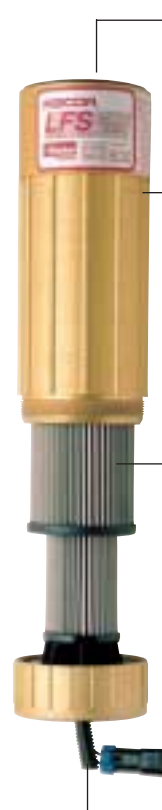

Spins directly onto existing filter heads. LFS spin-on models are available for Caterpillar, Cummins, Detroit Diesel, Mack and Navistar engines.

The rugged aluminium housing is designed for years and years of service. A high quality anodised finish means it will not rust or corrode.

Stainless Steel Wire Cloth Filter (Shown: LFS 700 dual element, wire cloth filter for Cummins engines using LF-3000 combination Full Flow/Bypass filter).

Standard light feature signals when it's time for service and eliminates unnecessary downtime.

Full-Flow Series Benefits

- 1 No more disposal worries
- 2 Eliminates filter inventory
- 3 Valuable diagnostic tool
- 4 Extends engine life
- 5 Quick and easy maintenance
- 6 One-time investment
- 7 Full-Flow with built-in bypass
- 8 Indicator Light signals the need for service

Remote-Mounted Full-Flow Cleanable Series

The Racor Remote-Mount LFS can be easily installed for convenient access on trucks, buses, off-highway and industrial equipment, and in marine engine rooms.



The rugged die cast aluminium construction is designed for years and years of service. A high quality powder coated finish means it will not rust or corrode.

A positive O-ring seal prevents contaminants trapped by the wire cloth filter from escaping down-stream where they can damage precision components. When the filter requires service, the service indicator light alerts the operator.

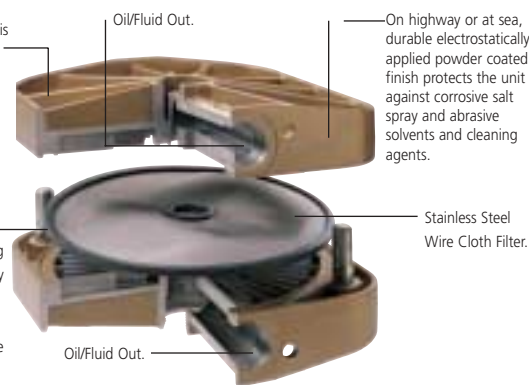

LFS Remote Mount Full-Flow Series Specifications

	LFS35	LFS60	LFS90
Flow Rate	23 lpm / 6 gpm	76 lpm / 20 gpm	170 lpm / 45 gpm
Maximum Pressure Diff.	10.5 bar / 150 PSI	10.5 bar / 150 PSI	10.5 bar / 150 PSI
Height	62.3 mm / 2.45"	83.9 mm / 3.50"	120.7 mm / 4.75"
Width	92.1 mm / 3.63"	152 mm / 6"	244.4 mm / 9.62"
Depth	92.1 mm / 3.63"	152 mm / 6"	241.3 mm / 9.50"
Weight	.55 Kg / 1.21 lbs	1.95 Kg / 4.31 lbs	5.69 Kg / 12.55 lbs
Ports	3/8" NPT	1 – 1/16" – 12 SAEJ1926	1 – 5/16" – 16 SAEJ1926
Micron Availability	28, 40	*28, 40, 60, 115	*28, 40, 60, 115
Service Indicator Light	YES	YES	YES

Notes: For accurate engine flow rates, consult your engine or equipment manual, manufacturer's agent or Racor distributor. Oil change frequencies are not affected and should be performed according to manufacturer's recommendations. The only accredited way to extend your oil change interval is through a formal lube oil analysis program, Racor part number LFS RK760.

*5, 10 micron available for LFS60, LFS90 bypass application.

Racor Bypass Oil Series



The Racor Bypass Oil Series removes dirt, varnish, ash, tar, soot and other contaminants down to one micron. The polishing effect of the Racor Bypass Oil Series and the use of the Racor Oil Analysis system will allow the engine oil service intervals to be extended. By reducing the disposal of waste oil, the system also contributes to preserving the environment.



Spin-on cartridge element is made of an efficient combination of a cotton and cellulose woven media.

Reusable spin-on steel canister mounted to a rugged aluminium head.

The engineered design of the filter element provides more efficient filtration for a significantly longer period of time than pleated cellulose, stacked disc and other cartridge filters.

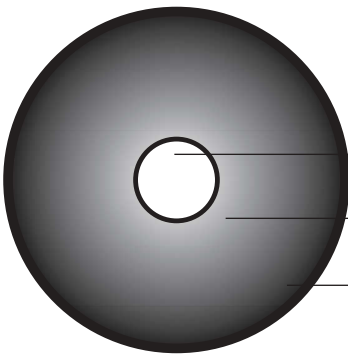

Oil flows inward through the graded density filter media

Cleansed Oil

1-5 Micron Filtration

35-40 Micron Filtration

Bypass Series Oil Filter Specifications

Part Number	LFS-800	LFS-801	LFS-802	LFS-820	LFS-825
Replacement Element (P/N)	LFS-800BPE	LFS-801BPE	LFS-802BPE	LFS-820BPE	LFS-825BPE
Engine Size/Horse Power	up to 150 hp	150 – 250	250 – 400	400 – 500	500 – 800
Sump Capacity	9.5 ltr / 2.5 gal	19 ltr / 6 gal	57 ltr / 15 gal	114 ltr / 30 gal	170 ltr / 45 gal
Flow Rate	.9 lpm / .3 gpm	1.4 lpm / .5 gpm	1.9 lpm / .5 gpm	3.8 lpm / 1 gpm	5.7 lpm / 1.5 gpm
Canister Cap	.5 ltr / .13 gal	.9 ltr / .3 gal	1.9 ltr / .5 gal	9.5 ltr / 2.5 gal	13.3 ltr / 3.5 gal
Orifice Size	1 mm / .040"	1 mm / .040"	1 mm / .040"	2.4 mm / .093"	2.6 mm / .101"
Port Size	3mm / 1/8" NPT	7mm / 1/4" NPT	7mm / 1/4" NPT	13mm / 1/2" NPT	13mm / 1/2" NPT
Height	14 cm / 5.5"	19.1 cm / 7.5"	27.9 cm / 11"	36.8 cm / 14.5"	50.8 cm / 20"
Width	10.2 cm / 4"	13.3 cm / 5.25"	13.3 cm / 5.25"	22.9 cm / 9"	22.9 cm / 9"

Bypass Oil Series Benefits

- 1 Extends the miles between oil changes
- 2 Saves maintenance costs and downtime
- 3 Keeps oil cleaner longer, reducing oil consumption and disposal
- 4 Extends engine life and "re-build" intervals
- 5 Keeps engines better lubricated which means reduced wear
- 6 Removes damaging water

Controlling Crankcase Emissions

In a robust, compact package, the patented Racor CCV4500 system provides superior oil coalescence and crankcase pressure control under the most severe conditions.

Pop up style indicator that alerts of a bypass condition and the need for a filter change.

Integral crankcase pressure regulator and internal bypass valve.

Left or right hand inlet/outlet options

High efficiency oil separation to 0.3µ (microns)

Durable glass filled nylon components.

Toolless element change.

High performance filter with depth loading, micro glass fiber coalescing media.

Extended filter service interval.

Powder epoxy coating

Maximum continuous operating temperature, -40°C TO 116 °C

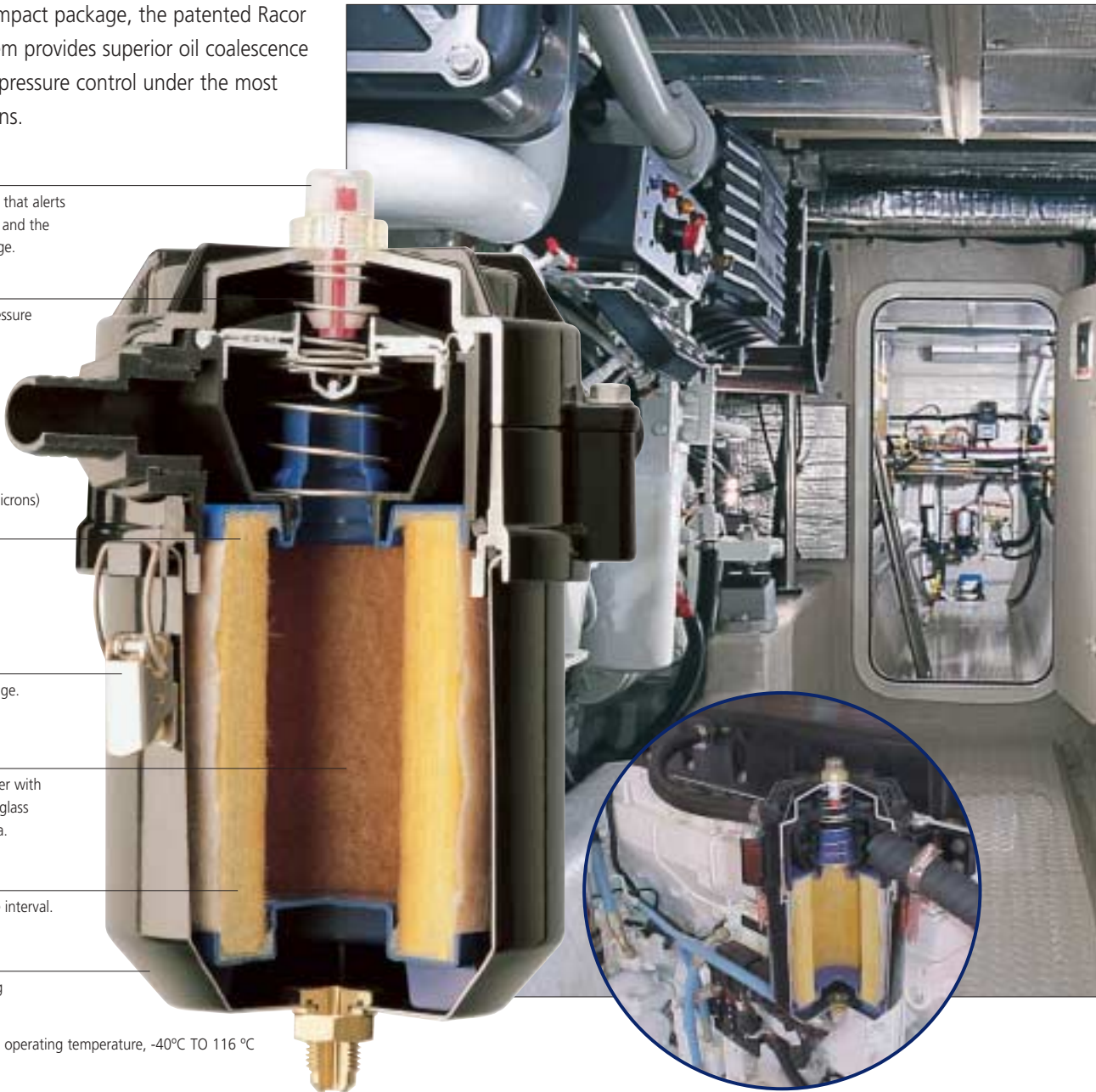

How it works

Blow-by gas is filtered and directed back into the combustion process via the engine air intake, often referred to as an ingestive system. Blow-by gas flows inside out through the filter element, then up and out of the filter assembly outlet to the engine combustion inlet. A drain in the sump allows the collected oil to be returned to the engine crankcase.

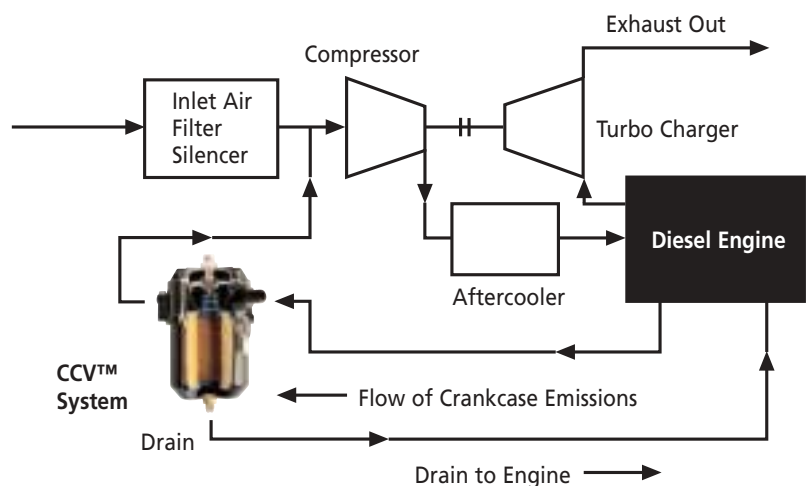



Environmental concerns about crankcase emissions from diesel and gaseous fuelled engines have increased significantly over the past ten years. To further reduce the total emissions of engines, it is becoming necessary to close the crankcase breather system, routing these gases into the air intake system. The crankcase blow-by is produced when combustion gases under pressure are blown past the piston rings into the crankcase. As these gases pass through the crankcase, they become contaminated with oil mist. This contaminated blow-by is vented out of the crankcase through the engine into the atmosphere on an open system. In a closed system, this contaminated blow-by is ingested by the engine intake system.

While the closed crankcase breather system offers the highest reduction in measurable emissions, the impact of unfiltered crankcase blow-by on engine components and performance must be considered.

- In closed environments like generator set and marine rooms, damage to surrounding equipment such as radiators and electronic control panels by oil mist can cause hazardous conditions, down time and expensive maintenance.
- Oil mist will coat and contaminate the aftercooler and other engine components. This coating reduces engine cooling capacity, causing a loss of engine performance and reliability over time, and shortens the useful service life of the engine components.
- The engine intake will inhale the contaminated gasses, clogging air filter systems and damaging turbocharger components. It is imperative that oil mist be removed from the crankcase emissions prior to introduction into the engine air intake – in closed breather systems.

Racor CCV™ systems offer engine operators a highly effective solution which is not only easy to install and maintain – but provides superior protection against contaminated crankcase blow-by.

By trapping crankcase blow-by and recycling engine emissions through its high performance, open cell foam filter, the Racor CV820 and CV1000 models trap the hazardous oily film that causes so many engine and environmental problems. Gone is the oily residue that used to coat engine compartments and equipment. Racor Crankcase Ventilation Systems (CCV) systems help decrease costs for maintaining air filters, turbochargers and aftercoolers. The CCV systems help engine components operate at full efficiency, improving performance and lowering the cost of operation.



Closed system Crankcase Filtration



	CCV1500	CCV3500	CCV4500	CCV6000	CCV8000
Height	5.1" / 130 mm	7.0" / 178 mm	9.25" / 235.0 mm	12.00" / 304.8 mm	13.88" / 352.6 mm
Max. Opening Width (incl. clamps & bracket)	8.2" / 208 mm	7.0" / 178 mm	7.50" / 190.5 mm	11.25" / 286.8 mm	13.25" / 336.6 mm
Depth	5.6" / 142 mm	6.3" / 160 mm	5.60" / 142.2 mm	7.30" / 185.4 mm	9.30" / 236.2 mm
Weight	1.5 lbs / .68 kg	2.3 lbs / 1.0 kg	3.26 lbs / 1.48 kg	5.01 lbs / 2.28 kg	8.72 lbs / 3.96 kg
Filter Removal Clearance	6.0" / 152 mm	4.6" / 117 mm	2.25" / 57.2 mm	4.00" / 101.6 mm	5.00" / 127.0 mm
Replacement Element/Media Density/Low	CCV 55365-04	N/A	N/A	N/A	N/A
Replacement Element/Media Density/Med.	N/A	CCV 55304-06	CCV 55248-06	CCV 55274-06	CCV 55222-06
Replacement Element/Media Density/High	N/A	CCV 55304-08	CCV 55248-08	CCV 55274-08	CCV 55222-08
Housing Material	Glass-filled nylon and black powder epoxy-coated steel bracket.	Glass-filled nylon components.	Die cast head, glass-filled nylon and black powder epoxy-coated steel bowl.	Die cast head, glass-filled nylon and black powder epoxy-coated steel bowl.	Die cast head, glass-filled nylon and black powder epoxy-coated steel bowl.
Inlet & Outlet Thread Size	3/4" hose	3/4" hose	1 3/16" - 12 STOR	1 5/8" - 12 STOR	1 7/8" - 12 STOR
Max. Cubic Feet per Minute	1 cfm / 30 lpm	3.0 cfm / 84 lpm	10 cfm / 283 lpm	20 cfm / 566 lpm	40 cfm / 1132 lpm
Crankcase Pressure Regulator	Vacuum limiting valve		Integral	Integral	Integral Integral
Bypass/Change Indicator	N/A	Integral	Integral or Remote	Integral or Remote	Integral or Remote
Engine Block Check Valve Return Fitting		N/A	1/4" NPT	1/4" NPT	1/4" NPT 3/8" NPT
Swivel Fitting (Qty.)	N/A	# 6 JIC (2pcs.)	# 6 JIC (2pcs.)	# 6 JIC (2pcs.)	# 8 JIC (2pcs.)
Oil drain hose I.D.	N/A	.375"	.375"	.375"	.5"

Additional details are available in technical manual #55021. * Units can be manifolded to handle higher flow rates.

Open System Crankcase Filtration



Crankvent CV820 and CV1000 Systems trap crankcase blow-by and recycle engine oil through a high performance, open-cell foam filter. They help to decrease costs for maintaining air filters and keeping engine rooms clean. These units are typically used as an 'open' system for non-turbocharged engines.



Model No.	CV820	CV1000 2
Diameter	6.00" / 152 mm	8.14" / 207 mm
Height	7.55" / 192 mm	8.48" / 215 mm
Weight	2.0 lbs. / 0.9 kg	3.0 lbs. / 1.4 kg
Filter Removal Clearance	4.00" / 102 mm	4.00" / 102 mm
Housing Material	Anodized aluminum All 18-8 stainless hardware	Anodized aluminum All 18-8 stainless hardware
Inlet Size	1" Female NPT	1-1/4" Female NPT
Outlet Size	1" Female NPT	1-1/4" Female NPT
Horsepower Range	Up to 350 HP (75–260 KW) ¹	350–600 HP (260–450 KW) ¹
Max. Cubic Feet per Minute	10 cfm / 283 lpm	15 cfm / 425 lpm
Service Kit	CV820 SK	CV1000 SK

For use on naturally aspirated engine.

(1) Use of two or more filters per engine allows higher flow.

(2) The Crankvent CV1000 must be used in two-cycle engines with air box drain applications.

Additional details are available in technical manual #7503 or please consult Racor.

Marine Air Filter / Silencers

- Reduces noise up to dba
- Can integrate Racor CCV systems
- Corrosion resistant
- Cleanable air filter
- No tools needed for serving
- Compact design



Air Filters/Silencers Family

Marine Air Filter Assembly

In order to determine the correct marine air filter application, you will need to know the marine air filter rating (AFR). You will need to provide the hose connection to turbo. Choose the correct marine air filter application per the following guideline:

Verify that the marine air filter dimensions will fit into your engine room.

4 cycle engines: $AFR = HP \times 2.0$ 2 cycle engines: $AFR = HP \times 2.5$

Note: If AFR is close to maximum capacity of the marine filter as listed below, use the next size larger.

Example: DDC 12V92TA DDEC (2 cycle – twin turbo):
 $826 \text{ hp} \times 2.5 = 1032.5 \text{ AFR per turbo} = (2) \text{ AF M501012}$
 $1110 \text{ hp} \times 2.5 = 1387.5 \text{ AFR per turbo} = (2) \text{ AF M601212}$
 CAT 3196 (4 cycle - twin turbo):
 $660 \text{ hp} \times 2.0 = 1320.0 \text{ AFR} = (1) \text{ AF M601212}$

In addition, note the dimensions of the marine filter outlets and the Racor CCV connector barb outside diameter from the chart in the Marine Air Filter Kit installation section to ensure the correct installation for your engine. However, the marine air filters typically correspond with the following CCV Models (see chart on right).



	AF M408512	AF M501012	AF M601212
Max. Air Flow*	800 cfm/377.6 l/s	1200 cfm/566.4 l/s	1600 cfm/755.2 l/s
Outlet Diameter	4.00"/101.6 mm	5.00"/127.0 mm	6.00"/152.4 mm
Filter Element	AF M8040	AF M8050	AF M8060
Length	12.50"/317.5 mm	12.50"/317.5 mm	12.50"/317.5 mm
Depth	9.59"/243.5 mm	11.14"/282.8 mm	13.51"/343.2 mm
Hose Barb size	1.00"/25.4 mm	1.25"/25.4 mm	1.25"/31.75 mm
Weight	4.16 lbs/1.89 kgs	5.03 lbs/2.28 kgs	8.00 lbs/3.63 kgs
CCV hose barb	1" OD	1 1/4" OD	1 1/4" OD
Operating Temperature	-40° to +240°F / -40° to +116°C		

*Values given are cubic feet per minute (cfm) and liters per second (l/s).

The engine crankcase breather is connected to the inlet of the Racor CCV assembly. The CCV outlet is connected to the engine's combustion air inlet via an air intake connector where filtered blowby gas is recycled through the combustion process. Oil collected in the CCV sump is returned to the crankcase through a hose and a drain check valve.

The Racor marine air filter/silencer removes contaminants introduced into the air from both outside and inside the vessel. Sand, salt, carpet fibers and other contaminants are trapped in the oil-impregnated filter media. Turbo noise is reduced by the unique design of the air filter/ silencer housing. An integral hose connection on the housing routes the clean blowby from the CCV back into the engine.

Marine Air Filter	CCV Model
AF M408512	CCV4500
AF M501012	CCV6000
AF M601212	CCV8000



Caterpillar 3196 marine engine with Racor CCV/AF System



Marine Air Filter/Silencer(AF) System

ECO® Series Spin-On Disposable Air Cleaners

With its revolutionary spin-on design, the completely disposable ECO Series offers faster, safer, more trouble-free service than any other air cleaner today. Built for rugged use, it combines maximum engine protection with fuel-efficient performance and long service life.

The ECO Series provides two significant improvements in engine protection. When the filter loads with dirt and replacement is required, collected dust and debris stay safely contained inside the disposable housing, eliminating the chance of contaminating the air intake system during air filter service. Since the ECO Series uses no clean air gaskets, you never have to worry about gasket leakage. The outlet simply hooks up to the intake with a rubber connection and clamp, creating a leak-tight seal.

Air flow distribution and dust loading are uniform throughout the high-performance filter cone pack, resulting in increased capacity and lower pressure differential for improved horsepower and fuel economy. All ECO Series Spin-On Filters feature water-resistant media for improved performance and optimum life.

Beaded outlet.

The first cone-type filter element that is both tapered and offset.

Water-resistant media provides three to five times longer filter life than conventional designs.

More usable media area than conventional filters.

Paper pleats are permanently locked in place for reliable performance.

Media is SAE-rated to provide average efficiency of 99.9% (SAE J726C), with no seals or gaskets to replace.

Requires no additional room to service element.



ECO-SM

- Choice of three inlet locations to match new or retrofit applications.

ECO-SE

- For light and medium duty applications; smaller mobile and stationary engines up to 300 hp.
- Durable urethane outlet eliminates additional rubber connection.

ECO-LL

- Spin-On disposable featured in a Long Life high-performance version.
- Choice of inlet locations.

ECOLITE

- Compact air cleaner with reverse flow flexibility.

ECO-BC

Slimline design for vertical installations requiring tight or limited space restrictions.

- Drain valve in base for water removal.

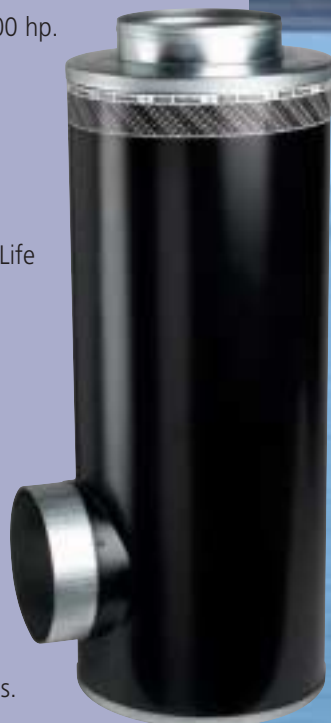

Pamic® Light and Medium Air Cleaners

UniPamic Series Air Cleaners provide unmatched engine protection for a wide range of equipment, from on-highway trucks to compressors, stationary engines to marine engines.

Greatest Protection

The Pamic filter element has an average efficiency rating of 99.9% (SAE J726). It begins at a high level and continues to increase throughout the life of the filter.

Extended Service Life

The unique construction of the Pamic element with its exclusive mechanical pleat separation, provides more usable filter area than any competitive air cleaner, thus offering longer element life. UniPamic models feature an efficient moisture separator panel which removes over 90% of the water that may enter the face of the air cleaner. AutoPamic® models can be upgraded to include a gravity-discharged dust pre-cleaner.

RotoPamic® models are upgradeable to either a compressed air or exhaust-aspirated pre-cleaner. An optional, easy-to-use service indicator tells when to change the filter element assuring maximum usage and lowest operating filter costs.



Increased Horsepower, Reduced Fuel Consumption

With its low intake air restriction and its greater effective media area than other dry-type air cleaners, the Pamic Series offers improved fuel economy and lowers per hour operating costs.

Easy To Service

No special tools or techniques, dirt is held inside the pleated filter element tubes. The filter is replaced from the dirty side of the air cleaner, reducing the danger of engine contamination. Because it is an integral part of the filter element, there are no separate gaskets to replace.



Moisture separator panel is all metal construction and removes in excess of 90% of water.

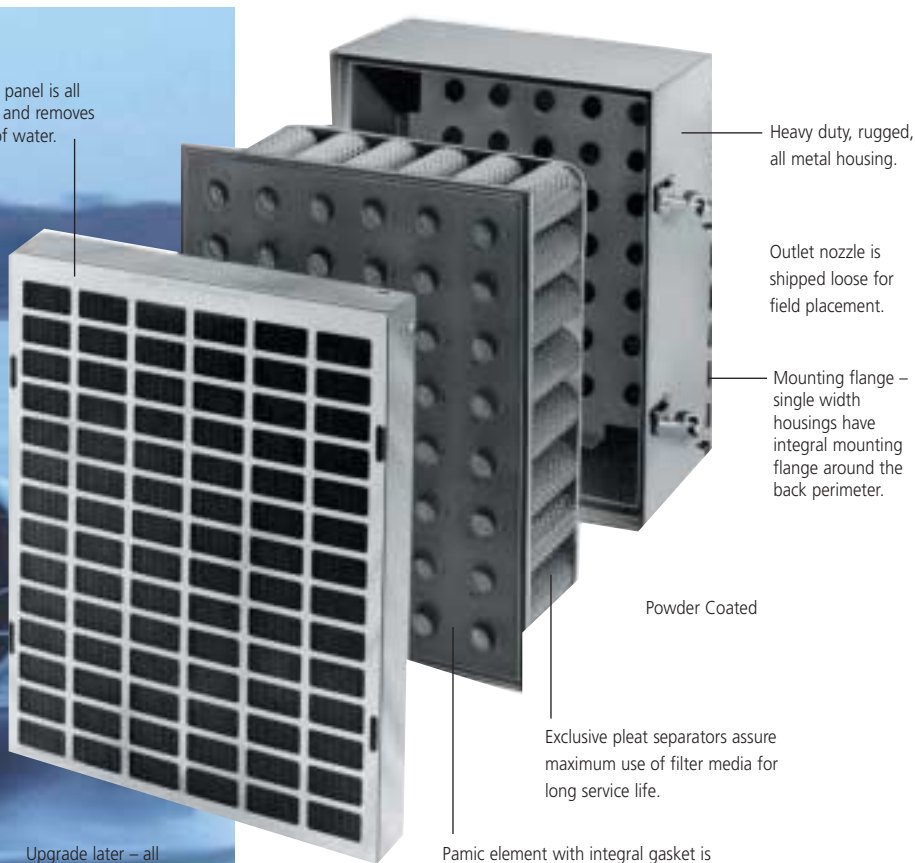

Heavy duty, rugged, all metal housing.

Outlet nozzle is shipped loose for field placement.

Mounting flange – single width housings have integral mounting flange around the back perimeter.

Powder Coated

Exclusive pleat separators assure maximum use of filter media for long service life.

Pamic element with integral gasket is easy to service.

Upgrade later – all Pamic air cleaners, except Slimline models, are easily upgraded for heavy or extra-heavy service simply by changing the pre-cleaner panel.



We've Bottled Racor Protective

Racor Additives are performance-enhancing products for all climates and seasons. There are several convenient sizes, including 1 and 2.5 gallon bottles and also a 16 oz. bottle that makes measuring quick and easy.

The high concentration of active ingredients in Racor additives allows for higher treatment rates. All Racor Fuel Additives are alcohol-free.

Diesel Biocide

Racor Diesel Biocide is a multifunctional petroleum distillate fuel additive. It is used to help maintain color stability and clarity; control bacteria, fungi, organic reaction and sludge formation; inhibit corrosion; and disperse existent sludge.

EPA Est. No. 072342-CA-001. EPA Reg. No. 1448-172-47099.

- Kills faster and longer and more forms of algae and bacteria than other brands
- Kills both aerobic and anaerobic fungi
- Concentrated, extended time formula
- EPA approved as both a biocide and aftermarket fuel additive
- Prevents internal corrosion from microbial fouling
- Provides superior mixing with fuel at all temperatures
- Fuel and water soluble
- Does not cause foaming



Diesel Performance Plus+

Racor Diesel Performance Plus+ has the same engine protection qualities of Racor Diesel Conditioner Plus+ and it has five times the Cetane improver to deliver optimal engine performance. The added performance comes with improved lubricity and is alcohol-free for better fuel system component protection.

All the features of Racor Conditioner Plus+ and:

- Five times the Cetane improver for faster starts and improved performance
- Lubricity improver passes HFRR Lubricity Test for diesel fuel per ASTM D6079-99
- Stabilizes fuel and prevents corrosion per ASTM D665A
- Four times the detergent additive for a clean fuel system



Gasoline Conditioner Plus+

Racor Gasoline Conditioner Plus+ is a diluted multifunctional gasoline additive which cleans as it protects. Racor Gasoline Conditioner Plus+ is designed for secondary treatment applications. It can be used with all types of internal combustion systems and gasoline blends. By cleaning the engine's fuel injectors and carburetor, it provides better combustion, better fuel economy and lower exhaust emissions.

- Protects intake system against corrosion
- Prevents accumulation of deposits
- Improves efficiency of fuel filter/water separators through demulsification
- Will not harm lube oil or catalytic converters
- Stabilizes quality of stored gasoline



Lube Oil Treatment

Racor Lube Oil Treatment is a fluorocarbon oil additive which contains an advanced, highly effective polymer lubricant. It provides a superior thin coating to protect precision engine parts, and does not contain PTFE or Teflon®, which have been known to fall from suspension and clog precision engine components. It may be used with diesel and gasoline engines and is compatible with all motor oils including synthetics.

- Reduces noise and heat in diesel and gasoline engines
- Anti-corrosion formula
- Increases mileage, engine life and performance
- Reduces friction on cold start-up
- Prevents premature wear on piston rings and cylinder walls, reducing harmful exhaust emissions





A convenient spout extension is available for quick, clean service. The spout fits 16oz. bottles only. Order part no. RK 21644.

Diesel Winter Plus+

Racor Diesel Winter Plus+ is added to middle petroleum distillates such as No. 2 heating oil or diesel fuel to improve their low temperature operability as measured by pour pint and cold filter plugging point. Racor Diesel Winter Plus+ prevents the plugging of lines, filter screens and valves and allows the fuel to flow freely down to -32° F (-32° C). Diesel Winter Plus+ contains a de-icer, which can help reduce line freezing.

- Improves fuel flow and facilitates cold weather starting
- Improves efficiency of fuel filter/water separators through demulsification
- Contains a cetane improver and de-icer
- Smoother, quieter engine operation
- Prevents corrosion
- Stabilizes fuel quality during prolonged storage



Coolant Treatment

Racor Coolant Treatment is a combustion corrosion inhibitor and iron oxide/scale dispersant. It's unique formulation protects all types of metals, including aluminum, in diesel and gasoline engine cooling systems.

- Stabilizes engine coolants helping prevent the formation of abrasive gel-like deposits
- Neutralizes hard water salts
- Contains an inhibitor to help protect all metals in the engine cooling system from corrosive attack
- Maintains heat transfer in closed cooling systems
- Helps prevent overheating
- Disperses silica deposits
- Contains an anti-foam agent



Diesel Conditioner Plus+

Racor Diesel Conditioner Plus+ is a multi-functional diesel fuel additive for all-season use. Its formulation contains a cetane improver which enhances power delivery, starting, and helps engines run smoother and quieter. Racor Diesel Conditioner Plus+ passes the Cunnins L10 superior rating for detergency as demonstrated in low and high sulfur fuel. Can be used in conjunction with Racor Biocide or Winter Plus.

- Contains lubricity additives to reduce friction; prevents wear and tear, extending engine life
- Dissolves gums and varnishes; keeps the injection system clean
- A clean fuel system provides improved fuel economy and lower emissions
- Reduces injector coking
- Reduces sediment formation which can result in reduced maintenance
- Reduces corrosion and rust formation in tanks and lines
- Improves efficiency of fuel filter/water separators through demulsification
- Contains a cetane improver
- Eases starting, increases power
- Passes the scuffing BOCLE test for lubricity
- Stabilizes fuel quality during prolonged storage
- Alcohol free



Part No.	Description	Size	gallons	Treats	litres
ADT 1116	Diesel Cond. Plus	16 ounces	320		1,210
ADT 1201	Diesel Cond. Plus	1 gallon	2,560		9,700
ADT 1325	Diesel Cond. Plus	2.5 gallons	6,400		24,200
ADT 1555	Diesel Cond. Plus	55 gallon drum	140,800		533,000
ADT 2116	Diesel Biocide	16 ounces	1,280		4,850
ADT 2201	Diesel Biocide	1 gallon	10,240		38,770
ADT 2325	Diesel Biocide	5 gallons	51,200		193,800
ADT 2555	Diesel Biocide	55 gallon drum	563,200		2,132,000
ADT 4116	Diesel Winter Plus	16 ounces	128		485
ADT 4201	Diesel Winter Plus	1 gallon	1,024		3880
ADT 4325	Diesel Winter Plus	2.5 gallons	2,560		9,700
ADT 4325	Diesel Winter Plus	55 gallon drum	56,320		213,200
ADT 5116	Gasoline Cond. Plus	16 ounces	320		1,210
ADT 5325	Gasoline Cond. Plus	2.5 gallons	6,400		24,200
ADT 5555	Gasoline Cond. Plus	55 gallon drum	140,800		533,000
ADT 7116	Lube Oil Treatment	16 ounces	2		7
ADT 7201	Lube Oil Treatment	1 gallon	16		61
ADT 7555	Lube Oil Treatment	55 gallon drum	880		3330
ADT 8116	Coolant Treatment	16 ounces	8		30
ADT 8021	Coolant Treatment	1 gallon	64		242

Water Detection Modules and Kits







Racor Water Detection Kits are available in a wide selection for various installation requirements. Under-dash, in-dash and remote mount, these solid-state units may be used with any Racor fuel filter/water separator and water probe. They are manufactured using the highest quality materials and are all 100% electrically tested.

An electronic detection module analyzes electrical resistance at the water probe and determines if water is present.

If so, the detection module operates to indicate water, based on its features listed below. All units reset automatically after water is removed (unless specified).

Caution: The water probe and detection modules work with 12 or 24 volts, direct current only and should never be wired to other brand modules or household 110 or 220 volts, alternating current.

Use the guide below to find the correct detection module for your application.

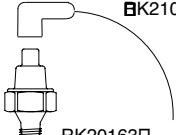
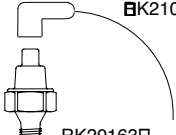
Kit Part No.		Use with the following voltage:	
RK12870	Under-dash Water Detection Module. Light and audio illuminates and sounds when water is detected. Water must be drained to reset light and stop horn. Plastic enclosure measures: 1.38" square x 1.25" deep.	12V DC	 RK12870 / RK12871
RK12871	Under-dash Water Detection Module. same as above.	24V DC	
RK20725	Under-dash Mount Water Detection Module. Light only. Green 'ON' lamp illuminates with power and red 'DRAIN' lamp illuminates when water is detected. Initial power-up self diagnosis feature and circuit protection included. Plastic enclosure measures: 2.75" x 1" x 1.5"	12V DC	 RK20725 / RK20725-24
RK20725-24	Under-dash Water Detection Module Same as above.	24V DC	
RK20726	2" Gauge Type Water Detection Module. Light and audio. Red 'DRAIN' lamp illuminates continuously and horn sounds momentarily when water is detected. Initial power-up self diagnosis feature and circuit protection included. Plastic case, satin black dial with white lettering.	12 or 24V DC	 RK20726
RK30056	2" Gauge Type Water Detection Module and Water Probe Kit. (Module RK20726 and Probe RK21069, with 1/2"-20 threads).	12 or 24V DC Bowl must have water probe port	 RK11-1570
RK11-1570	2" Gauge Type Water Detector & Filter Restriction Module. Includes pre-set vacuum switch (7in.Hg.), connector and outlet adapter fitting. Red 'DRAIN' or 'CHANGE FILTER' lamp illuminate continuously and horn sounds momentarily when water is detected. Probe not included. Steel case, black dial with white lettering.	12 or 24V DC For units with 7/8" SAE ports	 RK14329
RK14329	Remote Detection Unit. Sends 12V DC hot (+) signal when an input ground signal (from a water probe or a vacuum switch – not included) is received. Must be used with a relay to power a horn or indicator lamp (if draw is over 1 amp). Plastic enclosure measures: 3" x 2.5" x .75"	12V DC	 RK14332
RK14321	Remote Detection Unit. Same as above but sends 24V DC hot (+) signal.	24V DC	
RK14332	Under-dash mount. Same as RK14329 but sends a ground (-) signal. Enclosure size is same as RK20725, above.	12V DC	 RK14332
RK20163	Vacuum Switch Kit. 12 or 24V DC, non-adjustable, 'NORMALLY OPEN' contacts close at 7 in.Hg., 118" NPT threads. For use with all models.		 RK21030
RK21030	Vacuum Switch Connector Kit (for use with above). Molded connector with single 18 AWG., 18" blue wire lead.		 RK21030

Heavy Duty Marine

Marine Industry Filtration Solutions

Decades of intensive research, product development, refinement and manufacturing have resulted in a comprehensive range of products that Parker Hannifin Corporation offers to the marine industry.

Global solutions backed by experience, together with the innovations of our partners have resulted in product excellence. Continuous co-operation with major engine and propulsion systems, steering and winch manufacturers, refrigeration system designers through to passenger lift manufacturers and hydraulic system engineers have generated solutions that are unbeatable and irreplaceable in harsh conditions.

Related industries, such as offshore, with applications that include well-head lubrication, hydraulic systems and winch control provide ample opportunity for Parker Filtration to demonstrate quality in filtration manufacturing. Qualities that add up to reliable performance, long-term durability and efficient operation from bow to stern make Parker Hannifin Corporation a secure choice for all marine applications in all conditions.

Model BDK Duplex Filter

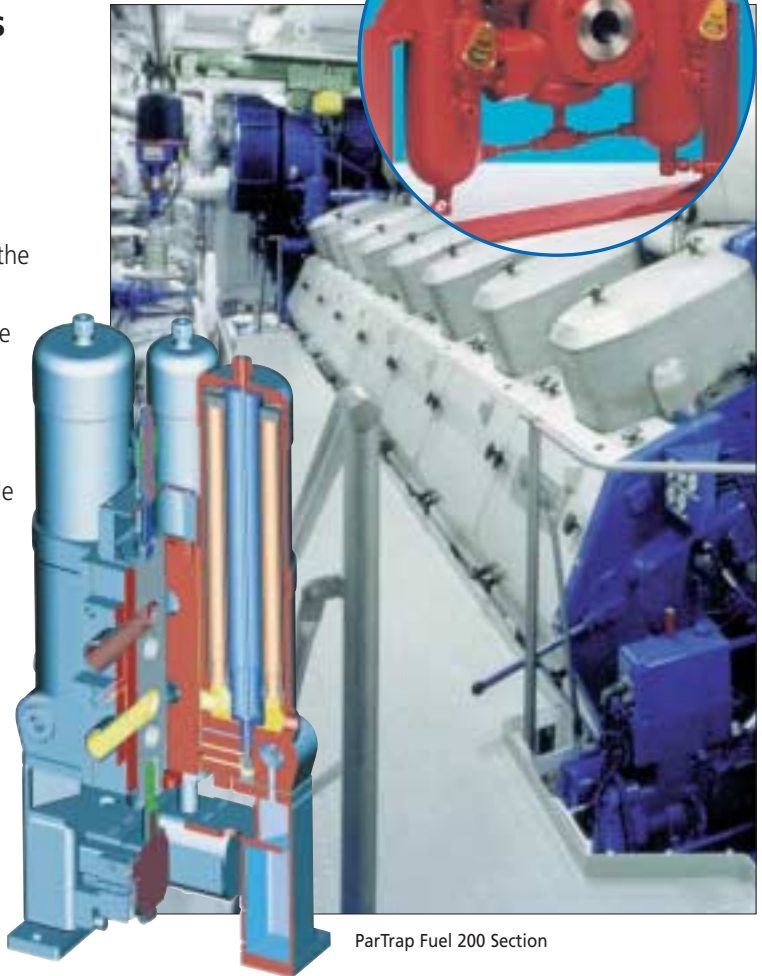

With the courtesy of Wärtsilä Corporation

LaserCM & H₂Oil



Range of Hydraulic Reservoir Equipment

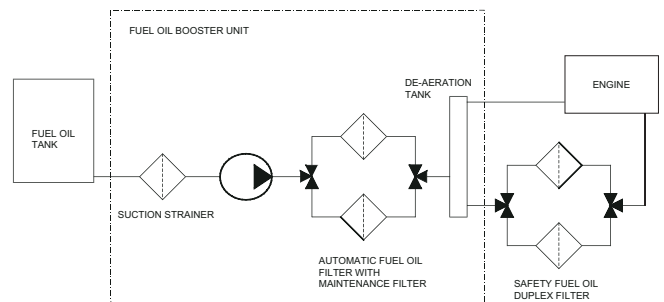

ParTrap Fuel 200 - the choice is automatic!

Parker has designed a new type of automatic fuel oil filter, ParTrap Fuel 200, which not only reduces the amount of fuel oil waste but also increases the efficiency of filtration and back flushing. First in a new generation of filter solutions - contact Parker Filtration to find out more.



7000T high pressure filter



FF 2040 lubrication filter



32 PD Duplex filter

Designing filters into a typical heavy fuel oil system

Parker Filtration has a solution for all fuel oil system needs. Experience has been gained over an extensive period of time while working and listening to the manufacturers and system designers both large and small. In fact, wherever there is marine manufacturing and production, Parker Filtration is your global partner in the industry.

Put our experience to the test As the leader in filtration, we're ready to have you put us to the test. For more information about Parker Filtration marine solutions, standard or customized, contact us now.



Parker Hannifin Corporation

Aerospace Group

A leader in the development, design, manufacture and service of control systems and components for aerospace and related high technology markets, achieving profitable growth through premier customer service.



Climate & Industrial Controls Group

Designs, manufactures and markets system control and fluid handling components and systems to refrigeration, air conditioning and industrial customers worldwide.



Fluid Connectors Group

Designs, manufactures and markets rigid and flexible connectors and associated products used in pneumatic and fluid systems.



Instrumentation Group

A global leader in the design, manufacture and distribution of high quality critical flow components for worldwide process instrumentation, ultra high purity, medical and analytical applications.



Automation Group

A leading supplier of pneumatic and electro-mechanical components and systems to automation customers worldwide.



Filtration Group

Designs, manufactures and markets quality filtration and clarification products, providing customers with the best value, quality, technical support and global availability.



Hydraulics Group

Designs, produces and markets a full spectrum of hydraulic components and systems to builders and users of industrial and mobile machinery and equipment.



Seal Group

Designs, manufactures and distributes industrial and commercial sealing devices and related products by providing superior quality and total customer satisfaction.

The name to trust in fuel filtration

Filtration Group Technical Sales & Service Locations

Parker Hannifin (UK) Ltd
Filter Division Europe
Shaw Cross Business Park
Dewsbury, West Yorkshire
WF12 7RD, UK
Phone: +44 (0) 1924 487000
Fax: +44 (0) 1924 487001
Email: filtrationinfo@parker.com

Parker Hannifin Corporation
Racor Division P.O. Box 3208
Modesto, CA 95353 USA
800/344-3286
209/521-7860
Fax 209/529-3278
<http://www.parker.com/racor>
e-mail: racor@parker.com

Worldwide Sales Locations

Argentina	+54 (11) 4752 4129
Australia	+61 (2) 9 634 777
Austria	+43 2622 23501-0
Belgium	+32 (67) 280900
Brazil	+55 12 3955 1000
Canada	+1 800 272 7537
Central & South America/Caribbean	+1 305 470 8800
China	+86 (21) 6445 9339
Czech Republic	+42 0 2 830 85 221
Denmark	+45 0 43 56 04 00
Finland	+358 (0) 3 54100
France	+33 0 254 741403
Germany	+49 2131-40160
Hong Kong	+852 (2) 428 8008
Hungary	+36 (1) 252 8137
India	+91 55907081 85
Italy	+39 02 451921
Japan	+81 3 6408 3900
Jordan	+(962) (6) 810679
Korea	+82 31 379 2200
Mexico	+1 800 272 7537
Netherlands	+31 0 541 585000
New Zealand	+64 (9) 573 1523
Norway	+47 64 91 1000
Poland	+48 225 732 400
Singapore	+65 688 76300
South Africa	+11 961 0700
Spain	+34 (91) 675 7300
Sweden	+46 8 5979 5000
Switzerland	+41 0 22 307 7111
Taiwan	+886 2 2298 8987
Thailand	+662 693 3304
United Arab Emirates	+971 2 6788587
United Kingdom	+44 0 1924 487000
USA	+1 800 272 7537
Venezuela	+58 212 238 54 22

NOTE: The (+) sign in front of the country code indicates that you may need to dial an additional prefix.

Distributor

For all other countries please contact:

European Product Information Centre **00800 27 27 5374**
www.parker.com/racor Email: filtrationinfo@parker.com

Parker
anything possible

RACOR